

★ **YODER SMOKERS** ★
COMPETITION GRADE BBQ PRODUCTS

OPERATION INSTRUCTIONS
PELLET SMOKER - YS 1500 (42")

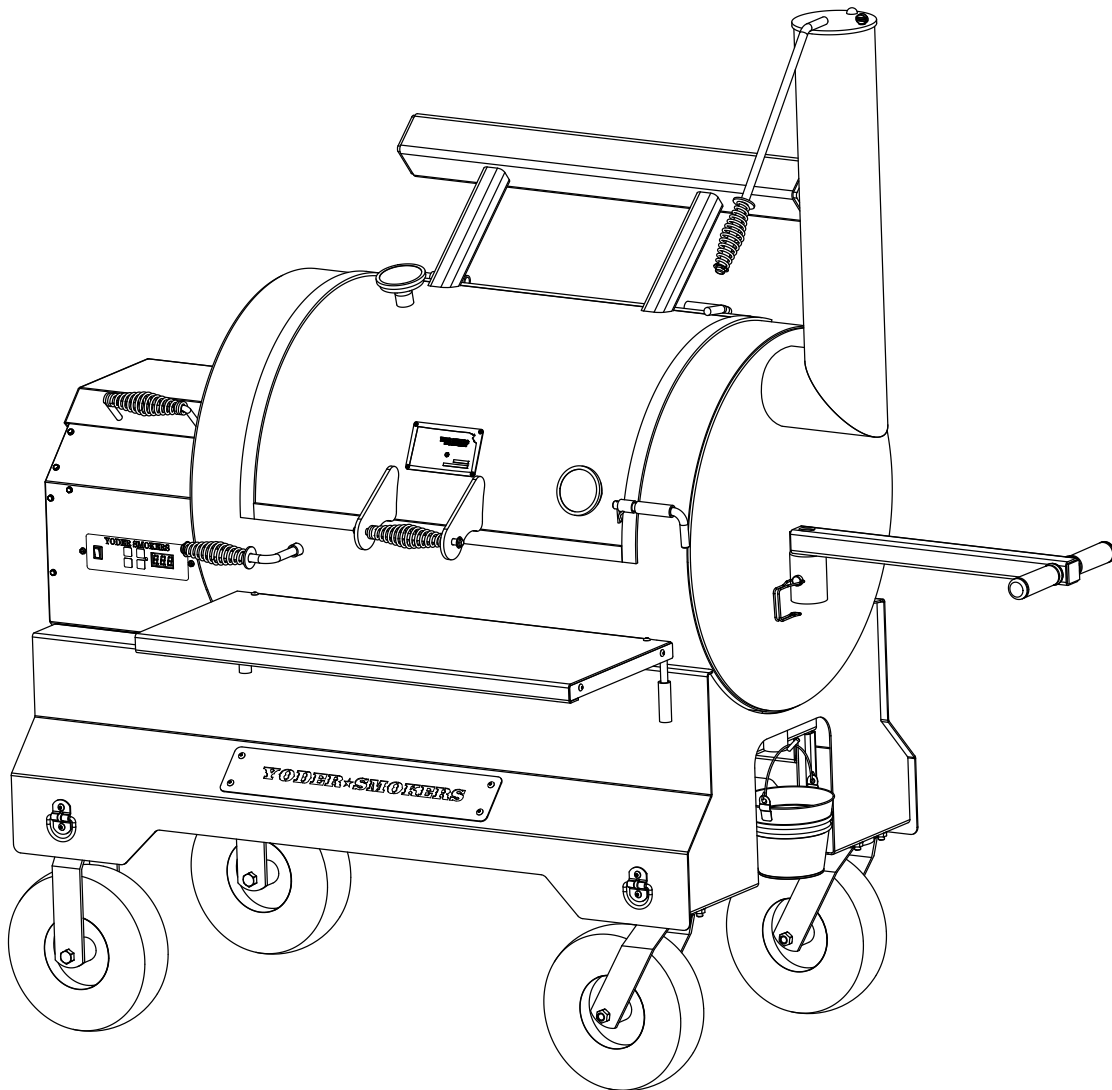

VERSION 1.2 , July 2014

YS 1500

Contents

Dangers, Warnings and Cautions.....	3
Yoder Components.....	5
Smoker Assembly.....	6
Smoker Arrival.....	6
Smoker Placement.....	7
Leveling the Smoker.....	8
Operating the Smoker.....	8
Initial Burn Off.....	8
Lighting Your Smoker.....	8
Pre-Heating.....	8
Lid Position/Smoke Stack Position.....	8
Pellet Usage.....	8
Yoder YS Series Control Panel.....	9
Selecting Heat Up Modes.....	10
Selecting Fahrenheit or Celcius.....	10
The Controller (In-Depth).....	12
How the Heat Up Modes Work.....	12
Faster Startup in Cold Weather or For High Temperature Cooking.....	13
Examples.....	13
Door Open Function.....	14
Prime Button.....	14
Pre-Grill Checklist/Routine Maintenance.....	15

YS 1500

Startup Procedure.....	18
Shutting Down the Smoker.....	20
Manual Startup.....	21
Getting the Most From Your Yoder: Direct & Indirect Grilling, Smoking & Baking.....	23
Heat Up Times and Grate Temperatures.....	23
Heat Management Plate.....	25
Grill Maintenance.....	26
Preparing the Grill For Season.....	26
Painted Surfaces.....	26
Cooking Grates.....	26
Heat Management Plate.....	26
Cooking Chamber.....	26
Firebox and Burn Grate Assembly Maintenance.....	27
Stainless Steel Burn Grate.....	27
Burn Grate Inspection.....	29
Igniter.....	29
Fan Cooled Hopper Assembly.....	29
Grease Management Area and Bucket.....	30
Additional Maintenance.....	30
Fuse Replacement.....	30
Storing Your Grill.....	31
Smoker Exploded View.....	32
Warranty Information.....	32

YS 1500

Dangers, Warnings and Cautions

Failure to follow the “Dangers, Warnings and Cautions” may result in serious bodily injury, death or in a fire.

- Read this manual **completely** before using your Yoder for the first time.
- Keep the grill a **minimum** of 12 inches away from combustible surfaces.
- The cooking chamber door must remain closed during the cool-down cycle. Failure to do so can cause burn back in the hopper.
- Do **not** modify the holes in the burn grate.
- Do **not** add pellets by hand to the burn grate when the grill is in use.
- Do **not** use your grill in the rain or around any source of water.
- Do **not** leave your grill unattended during operation.
- Do **not** transport your grill while operating or when the grill is hot. Make sure the fire is out and the grill is cool before moving.
- Exterior surfaces on the grill will be **hot** when in use and during cool down.
- Unplug the grill before performing any routine service or maintenance.
- Should a grease fire occur, turn the controller to the “off” position and unplug the unit to stop the fans. Keep the lid closed until the fire is out.
- If the Yoder goes out during operation (due to a power surge or power failure) do not restart the Yoder without removing the cooking grates and heat management plate to check for a pellet overflow that may have occurred.
- Do not store the grill cover or other flammable items under or near the grill.
- After a period of non-use, the hopper, auger and firepot must be inspected for obstruction.
- Use heat resistant gloves when operating the grill.
- If your grill is stored outside, care should be taken to assure that water does not enter the pellet hopper. (The use of a grill cover is highly recommended).

YS 1500

- When you are finished cooking, turn the power switch to the “off” position. The fan will continue to run for 18 minutes or until the temperature inside the cooking chamber falls below 125° F., whichever occurs first. During this period the cooking chamber door must remain closed. **Failure to do so can cause burn back in the hopper.**
- Check the Yoder website (www.YoderSmokers.com) occasionally for updates and new product information for the Yoder.

YS 1500

Yoder Components

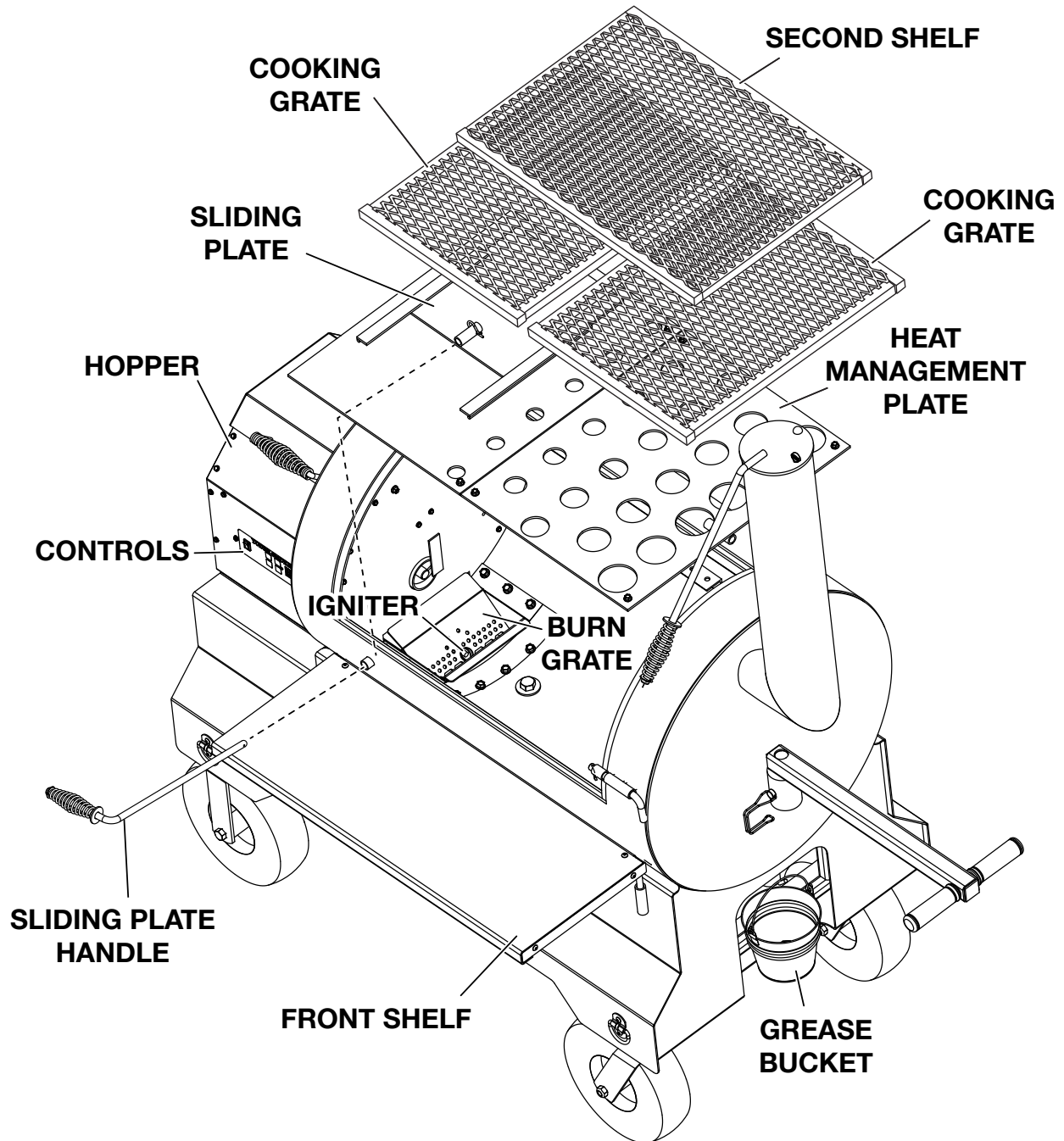

YS 1500

Smoker Assembly

Smoker Arrival

Your Yoder Smoker will arrive on a pallet wrapped and held on with metal bands. Cut the bands and remove the plastic wrap and foam from the smoker. Remove the smoker from the pallet. It is recommended that two people remove the Yoder from the pallet due to its size and weight. Open the hopper lid and remove the grease bucket that contains the power cord and a spare fuse and set aside. Open the cooking chamber and remove all the wrapped components. There will be a front shelf, two cooking grates, a second shelf, a heat management platet, and burn grate.

NOTE: If a bag of pellets were ordered they will be in the cooking chamber as well.

Assembly of your new Yoder starts by installing the burn grate inside the firebox. See **FIG 1**.

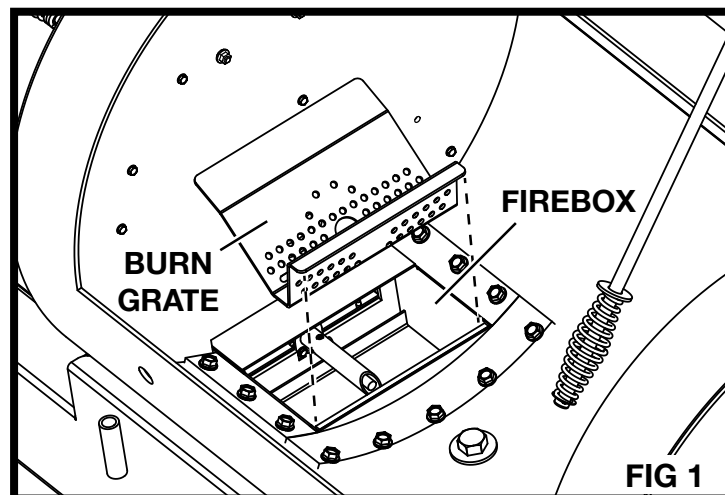

Install the heat management plate second. See **FIG 2**.

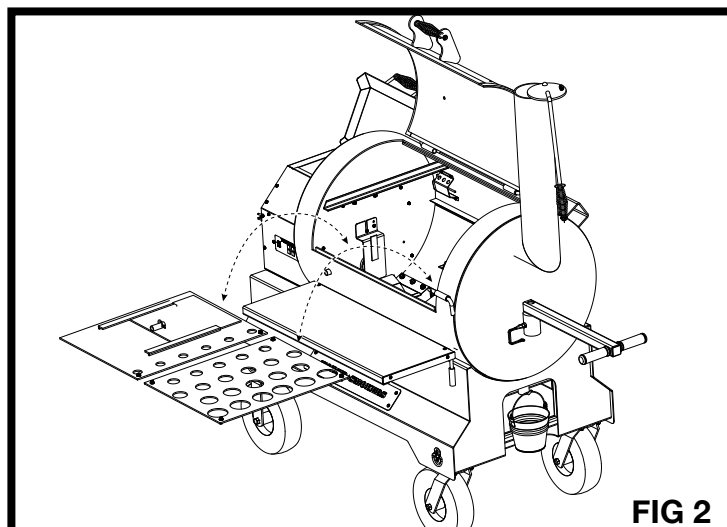

YS 1500

Place the cooking grates and second shelf inside the cooking chamber. See **FIG 3**.

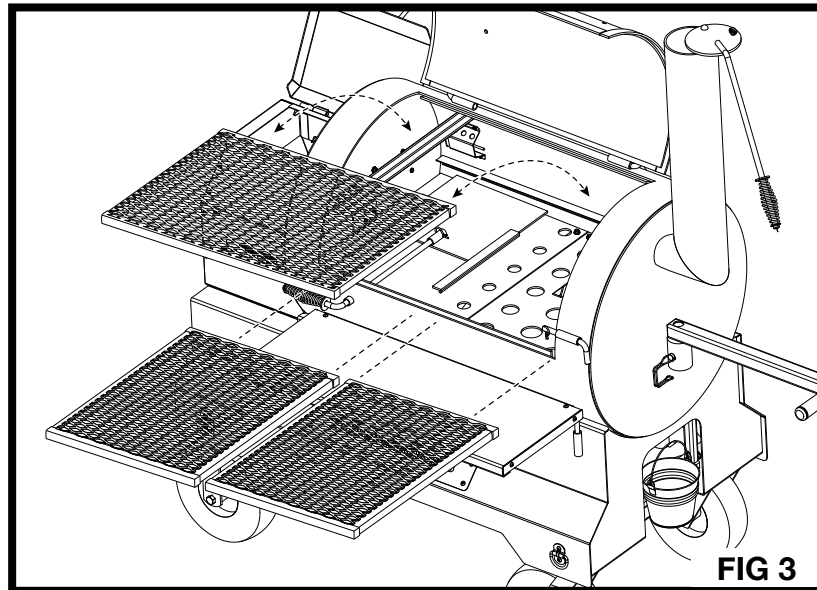

Attach the front shelf to the Yoder. See **FIG 4**.

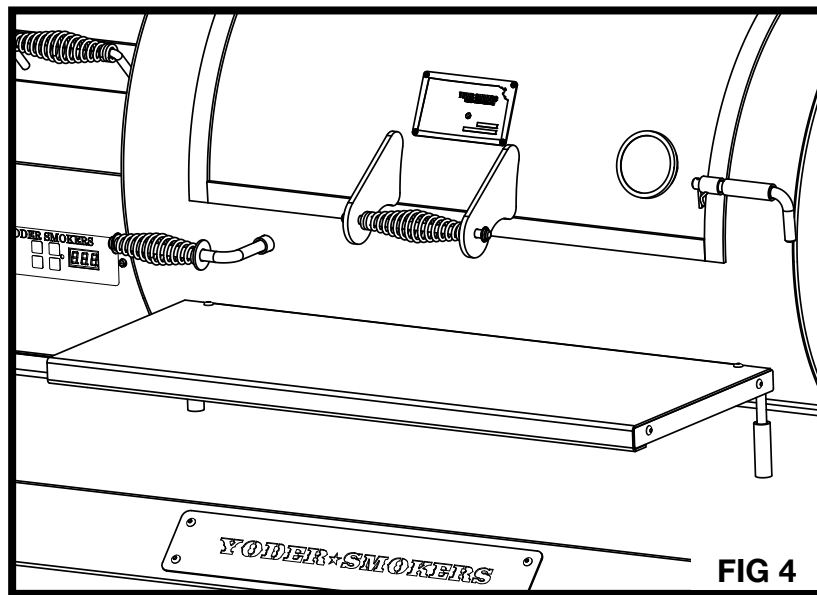

Use the side handle to assist in moving the Yoder into position. It is recommended that two people move the Yoder due to its size and weight. Once in position, follow the set-up instructions (Page 15) to prepare your new cooker for use.

Smoker Placement

All Yoder smokers/grills should always be a minimum of 12 inches away from any combustible surface (wall, deck, rail, etc.). A heat protective pad is recommended if the smoker is on a wooden deck.

YS 1500

Leveling the Smoker

The smoker must be level front to back and side to side. Use a level to help you with this. If the smoker is not level there could be problems with grease running towards the burn grate which could result in a grease fire.

Operating the Smoker

Initial Burn Off

Before cooking on your smoker/grill for the first time, burn off the grill to rid it of any foreign matter. Follow the instructions on Page 18 for initial start-up. Operate the grill at 350°F with the heat management plate and grates in place with the lid closed for one hour.

Lighting Your Smoker

Always go through the Pre-Grill Checklist (Page 15).

Should the igniter fail to ignite the pellets, it is easy to light your grill manually with a match and lighting agent (Page 21).

Pre-Heating

There are two ways to cook on your Yoder grill. When the grill is set up for direct cooking, start the grill 10 to 15 minutes prior to cooking. When the grill is set up with the heat management plate in place, start the grill 20 to 30 minutes prior to cooking. This allows the body of the grill to heat up improving heat retention and shortening the recovery time after opening the cover.

Lid/Smoke Stack Position

Preheat the cooker with the lid closed and the smoke stack open. This allows for faster heat-up and keeps the cooking temperature even; the food will cook faster while using less fuel.

Pellet Usage:

Pellet usage will vary depending on the type of pellets, cooking temperatures, ambient air temperature and wind. Generally, usage is about two pounds per hour at grilling temperatures (350 to 450° F.). At smoking temperatures (225 to 250° F.) usage is about 1 1/2 pounds per hour. Consumption can vary from 1 1/2 pounds to 4 pounds per hour.

NOTE: If the Yoder runs out of pellets, the controller will continue to drive the auger and attempt to regain the set temperature so it's important to monitor the cooker and assure an adequate pellet supply.

YS 1500

Yoder YS Series Control Panel

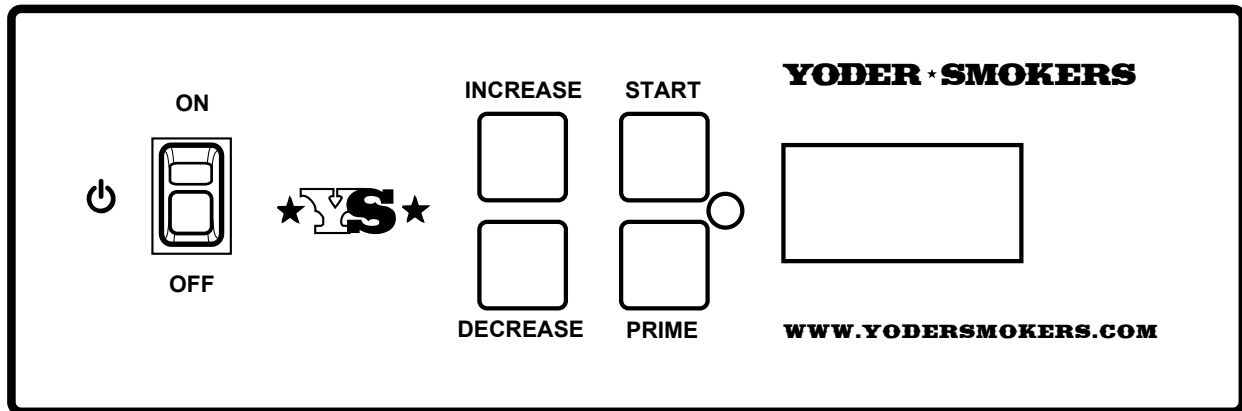

1. Power Switch - turns the power to your Yoder on and off
2. Increase - increase the temperature setting (in five degree increments).
3. Decrease - decrease the temperature setting (in five degree increments).
4. Start - activates the startup cycle. This also accesses the “heat up” modes (see below).
5. Prime - overrides the control system to manually feed pellets.
6. Power LED - lights up when the power switch is in the on position.
7. Display - provides information about how the grill is performing including: heat up mode, cool down mode, maintenance mode, set temperature and actual temperature. Once the cooker exceeds 110°F. at start up the display alternates between the cooker temperature and the operating mode.

The controller is adjustable from 150 to 600°F in five degree increments. The controller displays the actual pit temperature when the set point is from 150 to 495°F. When the controller is set over 500° F the controller will display the set point.

To access the “heat up” modes once the Yoder is running press and hold the start button until the current heat up mode is displayed. Use the increase/decrease buttons to toggle between H1, H2 or H3.

Operating mode indicators: Heat up mode (**FIG 5**) is displayed by three dashed lines from lower left to upper right. Maintenance mode (**FIG 6**) is displayed by three horizontal lines. Cool down mode (**FIG 7**) is displayed by three dashed lines from the upper left to the lower right.

NOTE: For startup in temperatures below 50 degrees see Page 13.

YS 1500

Selecting the Heat Up Mode:

- Initiate the startup procedure by pressing the start pad.
- Select desired cooking temperature.
- Press the start button, the display will flash H1.
- Use the increase/decrease buttons to select H2 or H3.
- Once the new mode is selected the controller will automatically run the selected mode.

Selecting Fahrenheit or Celsius:

Note: Only available on models outside the United States.

- Initiate the startup procedure by pressing the start pad.
- Press the start button, the display will flash H1.
- Press and hold the start button. The display will show F. or C.
- Use the increase/decrease buttons to select Fahrenheit or Celsius.
- Once the new mode is selected the controller will automatically run the selected mode. The default temperature display is Fahrenheit.

YS 1500

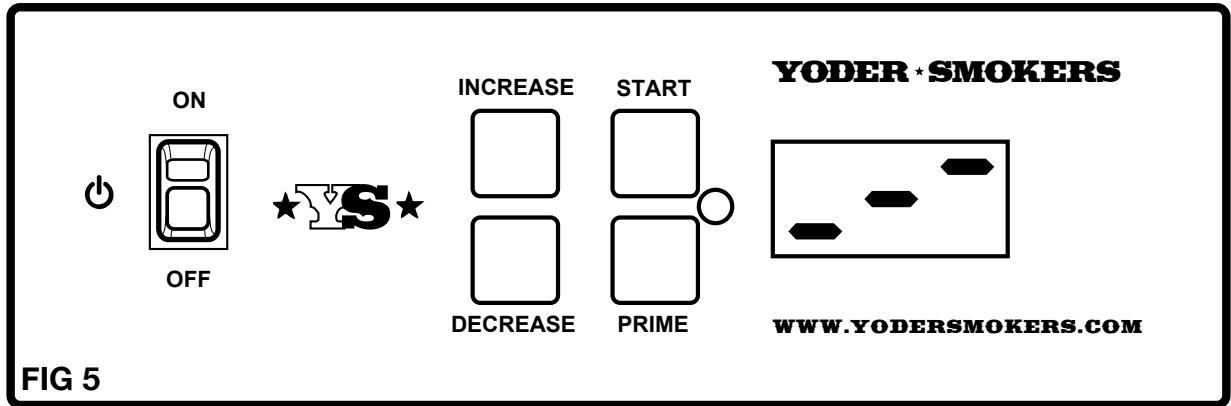

Heat Up

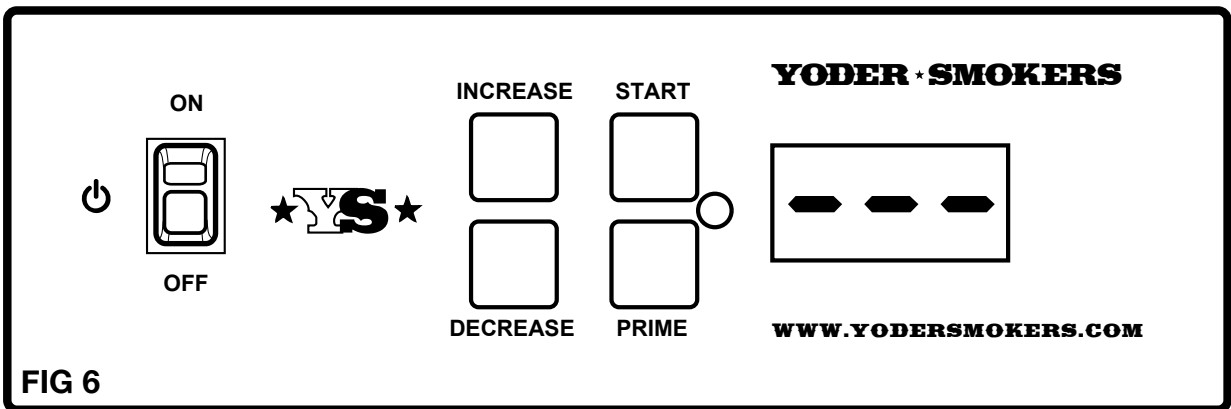

Maintenance

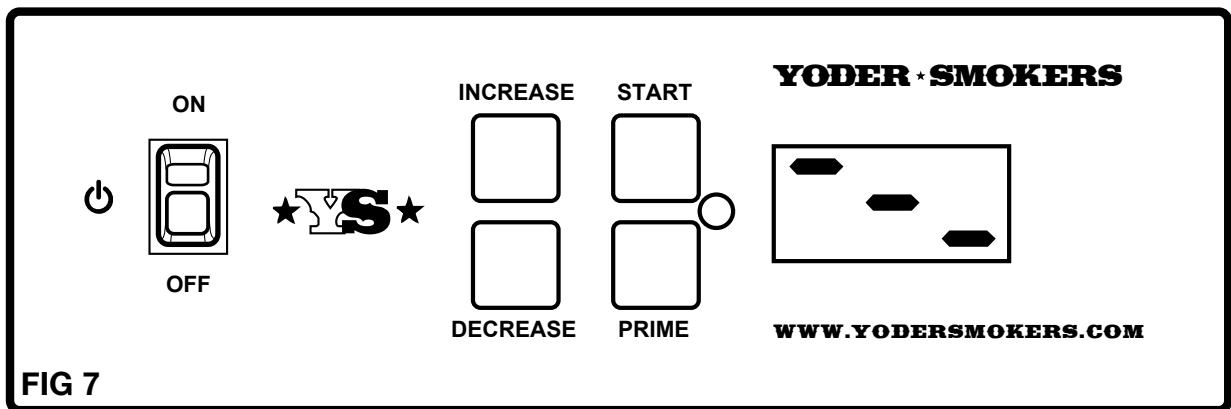

Cool Down

YS 1500

The Controller... In-Depth

This is an in-depth overview of the controller's feature set.

The controller has been designed to make it as hands-off and user-friendly as possible. At its most basic level, the cooker has three modes of operation: Heat up, Maintenance and Cool Down.

Beyond these basic modes are the concepts of aggressiveness, anticipation and micromanagement that have been learned as the result of many thousands of hours of testing. When the cooker is displaying maintenance mode, it is not idle. It is constantly checking and re-evaluating the grill's temperature and making incremental adjustments to maintain the cooking temperature as close to the desired set point as possible – think of it as micromanagement.

Just like in the maintenance mode, the controller is constantly evaluating the grill status while in “heat up” and “cool down” modes. This is where “aggressiveness” and “anticipation” have been written into the program. If the controller senses the grill is not heating up very quickly, it will increase the pellet feed rate above what the normal heat up rate would be for a given set point, and it will continue to do so until the heat up rate is where it should be. The inverse is true of the cool down mode – if the grill is not cooling fast enough, the controller will get more aggressive with cool down until the grill temperature is where it should be.

How the Heat Up Modes Work

In addition to the intelligence previously described, the program also contains three internal heat up modes. Left on its own, the controller makes a series of small incremental adjustments as described above. The various heat up modes are designed to speed the heat up process.

The selection of the heat up modes is automatically selected by the program. At start-up the program automatically begins in H1, eight minutes into the startup cycle the program calculates the difference between the set point and the actual cooker temperature and changes the “H” mode if necessary. The program will make the same calculation again at the 12-minute mark, and if an “H” mode other than the mode currently running is required, the program makes the required change. If a mode other than H1 has been selected it will remain in that mode until it breaks that target set point at which time the program will enter maintenance mode.

Once the controller enters maintenance mode, the pit temperature must rise or fall 35 degrees above or below set point before the program enters the heat up or cool down mode.

YS 1500

Faster Startup in Cold Weather or For High Temperature Cooking

Even though the heat up mode is automatically selected, the cook can benefit from starting the pit in “H2” when the outside temperature is below 50° F., this will provide a more aggressive start over the first eight minutes. Secondly, if the target temperature is greater than 350° F. starting the pit in “H3” will get the pit to temperature much quicker.

Examples

Ambient temperature of 70° F. and a set point of 350° F.:

All of the pre-grill steps have been taken; turn the power switch to the “on” position and press start. The display will alternate between the heat up (mode lines) and the set temperature (set point). The display will continue in this manner until the cooking chamber temperature exceeds 110° F. at which point the display will alternate between the mode lines and the actual cooker temperature. In about three minutes there will be evidence of ignition.

In the scenario listed above it is likely that the program will stay in “H1” through the startup cycle. In this case the “mode lines” will come out of heat up and into maintenance before the set point is reached. This does not indicate that the program is no longer working to achieve set point. It is simply doing it in a less aggressive way.

When “H2” or “H3” is selected it is common for the pit to overshoot the set temperature. How much overshoot depends on the startup (initial pellet drops and ignition, and ambient conditions including wind and temperature). The program will make the adjustments and begin bringing the temperature down. It is also common for the grill to undershoot the set point and then work its way into the target temperature range. We call this process normalizing, which is the time it takes to raise the cooker’s body temperature to match the internal temperature.

NOTE: When the grill overshoots or undershoots some cooks want to jump in and begin making temperature adjustments. Do not make adjustments. When you do, the program will begin making adjustments to the new set point rather than finish settling into the intended temperature range. With experience comes the confidence of knowing how the cooker operates.

Also remember, no matter how small a pellet is, it is still wood, so understand that the controller is managing a wood fire which does not have the precision of gas or electric.

One last point on the subject of temperature management, if you have a grate (pit) probe in place, especially during heat up process, the grate probe will read higher than the display until the temperature of the cooker body and the internal temperatures stabilize. The reason for this is that the temperature displayed is a 90 second rolling average and will lag behind actual until the set point is reached.

YS 1500

Door Open Function

When the cooker has been in maintenance for more than 10 minutes and the cooker loses more than 15 degrees, the program interpretes this as the cooking chamber door has been opened. When this happens there is a specific piece of programming that is executed to help to quickly recover and get back to the set point.

Prime Button

The prime button overrides the program altogether and turns the auger continuously, feeding pellets as long as the button is depressed. This is valuable anytime you have had the door open for a long time and have lost significant temperature or if you want to raise the cooker temperature from say 250 to 350° F. To use this function hold the prime button, 60 seconds on and then 60 seconds off. You may repeat this twice allowing at least two minutes before repeating.

YS 1500

Pre-Grill Checklist/Routine Maintenance

Perform the following services when the grill is cool

1. Open the cooking chamber door and remove the second shelf and cooking grates.

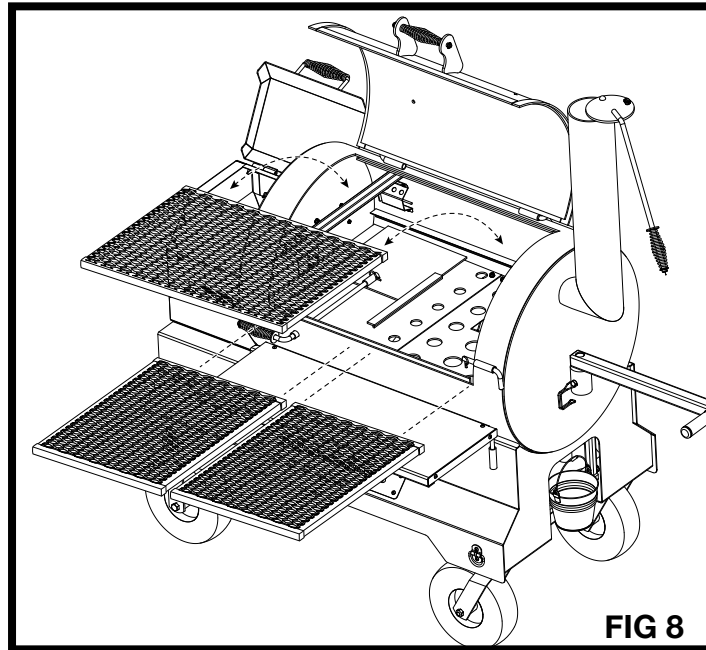

2. Remove the heat management plate.

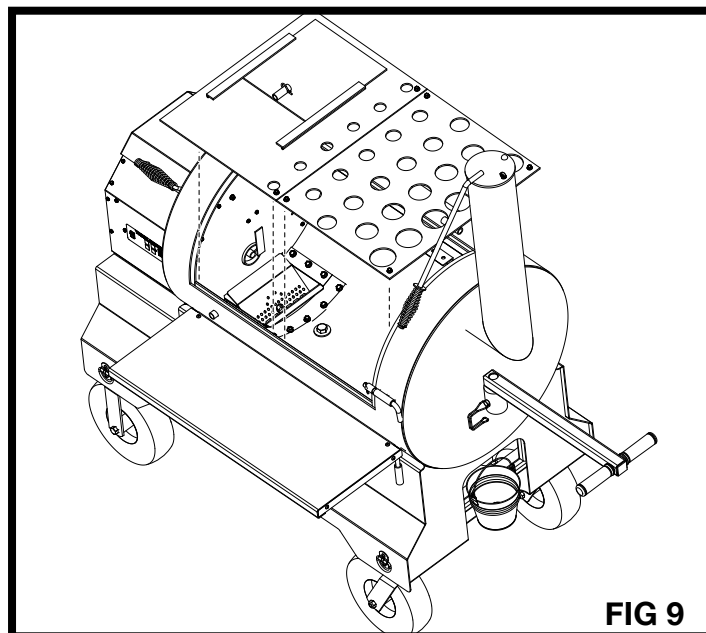

YS 1500

3. Remove the burn grate from the firebox. Inspect and clean thoroughly. Make certain that the combustion holes in the burn grate and the igniter tube in the firebox are free of debris or ash build up. Visually inspect the air way between the combustion fan and the firebox to be certain that it is free and clear of ash and debris. (A shop vacuum works well for ash and debris removal.)

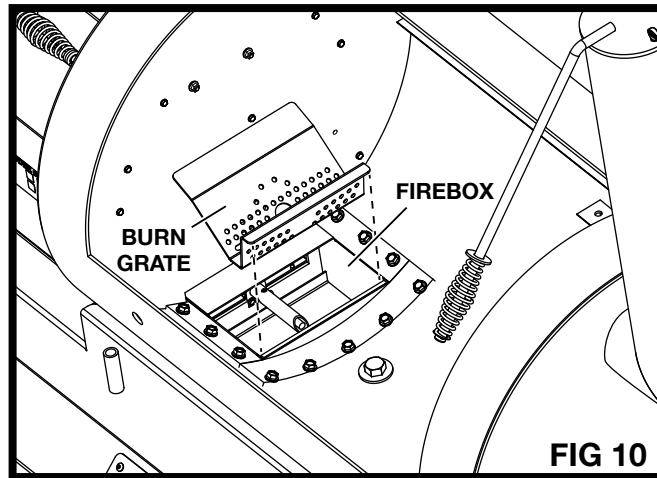

4. Inspect for and remove any grease build up on the bottom of the cooking chamber.
5. Inspect the silicone seal around the firebox, paying particular attention to the seal above the firebox at the hopper wall. It will be necessary from time to time to reapply high heat silicone such as **Permatex 81878** in this area which insures proper combustion and grill performance.
6. Reinstall the burn grate. Begin by resting the right hand side of the burn grate on the firebox and then pressing down on the left hand side of the burn grate until fully seated. When the burn grate is properly seated it rests firmly on the right hand side of the firebox and fits close to the hopper wall. Finally, check that the igniter assembly is centered in the respective hole in the burn grate.

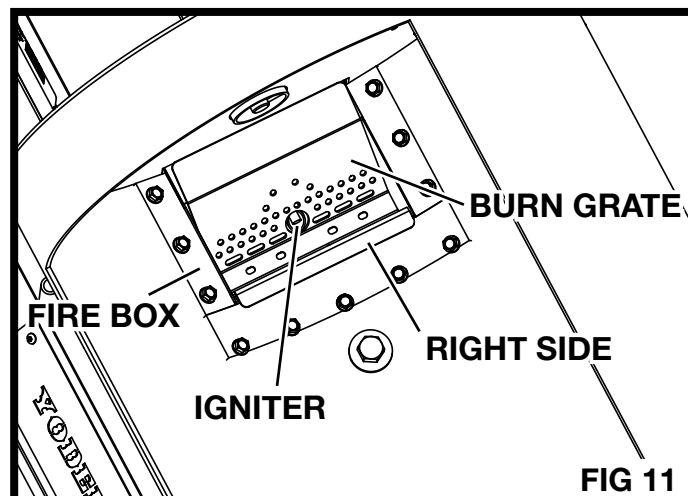

YS 1500

7. Reinstall the heat management plate. There are two brackets in the right side of the cooking chamber, two in the center and an auger shield. This is what the heat management plate sits on. Take the right side heat management plate and line the bolts up with the right side and center mounting brackets within the chamber and set in place. See **FIG 12**. Take the left heat management plate and line up the bolts with the middle mounting brackets and the left side will sit on the auger shield. Once installed check to be certain that the edges are approximately one-quarter inch below the grate rails. See **FIG 13**.

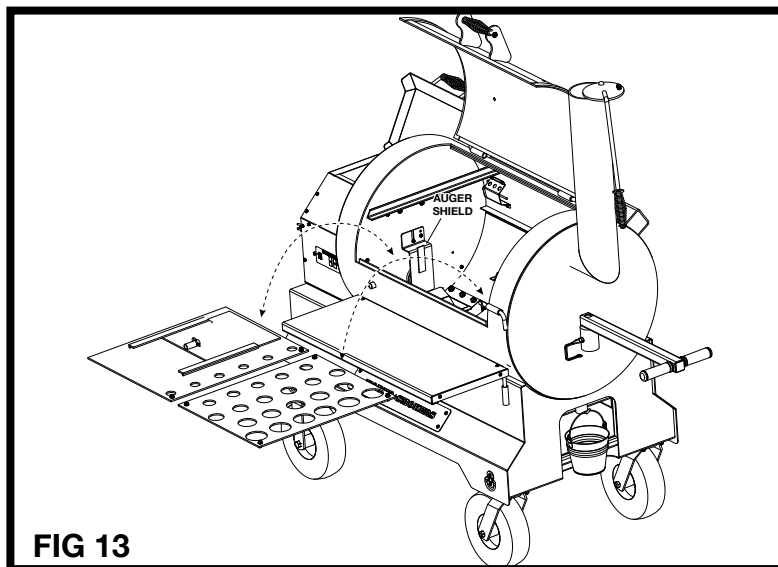
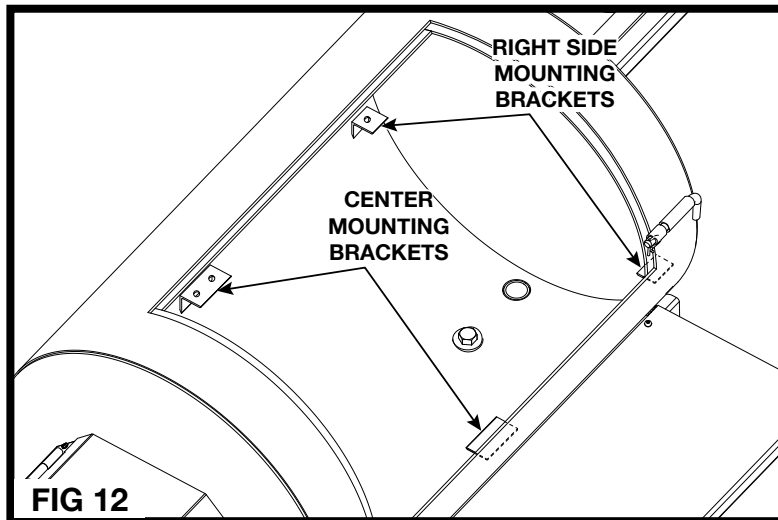

8. Reinstall the cooking grates and second shelf. See **FIG 8**.
9. Remove, inspect and clean the grease bucket as needed. Reinstall the grease bucket under the right side of the grill.
10. Open the hopper lid and inspect for any foreign materials.
11. Continue to Startup Procedure.

YS 1500

Startup Procedure

(When using the Yoder with the heat management plate in position, it is best to start your grill 20 to 30 minutes prior to cooking. This allows the grill and cooking grates to heat completely improving heat retention and recovery when opening the cover during cooking.)

1. Confirm the power switch is in the “off” position.
 2. Plug the female end of the cord in the receptacle on the back of the pellet hopper. Plug the male end into a 120 volt 15-amp GFI-protected outlet. If an extension cord is required, use a 14-gauge or heavier cord. (On startup, the Yoder will draw about three amps of power; during cooking the draw is less than one amp.)
 3. Load the hopper with “food grade” pellets. **DO NOT** use heating grade pellets. The hopper will hold 20 pounds of pellets allowing five to 13 hours of cooking depending on cooking temperatures, ambient temperatures, wind condition and whether or not the optional thermal jacket is installed.
 4. Open the cover over the smoke stack.
- NOTE: Smoke stack should never be more than half closed during smoker use.**
5. Open the cooking chamber door.
 6. Remove the cooking grates and heat management plate.

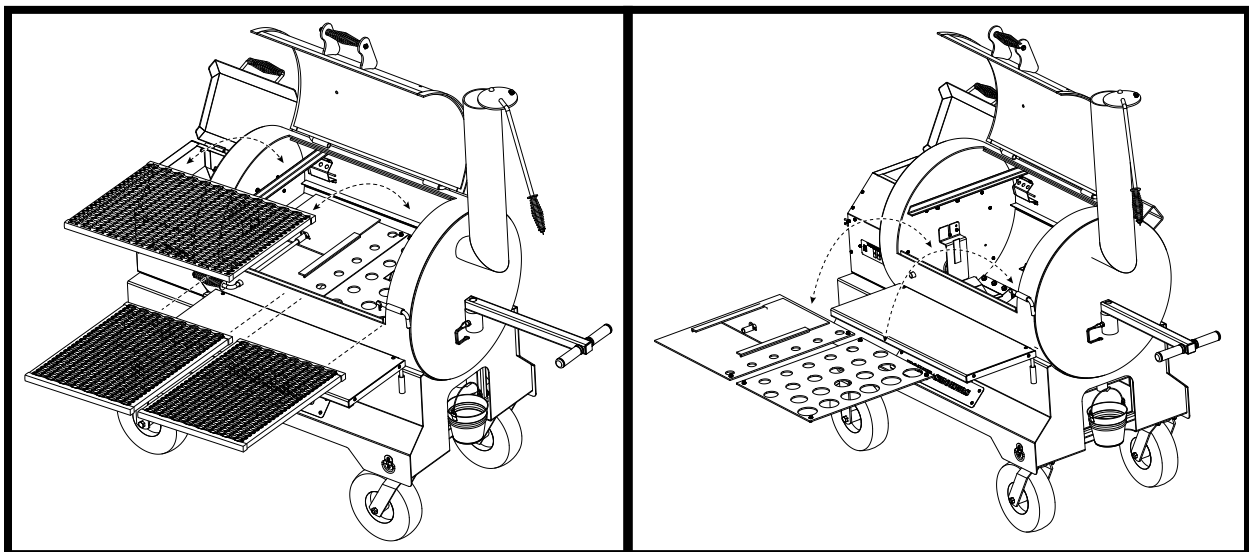
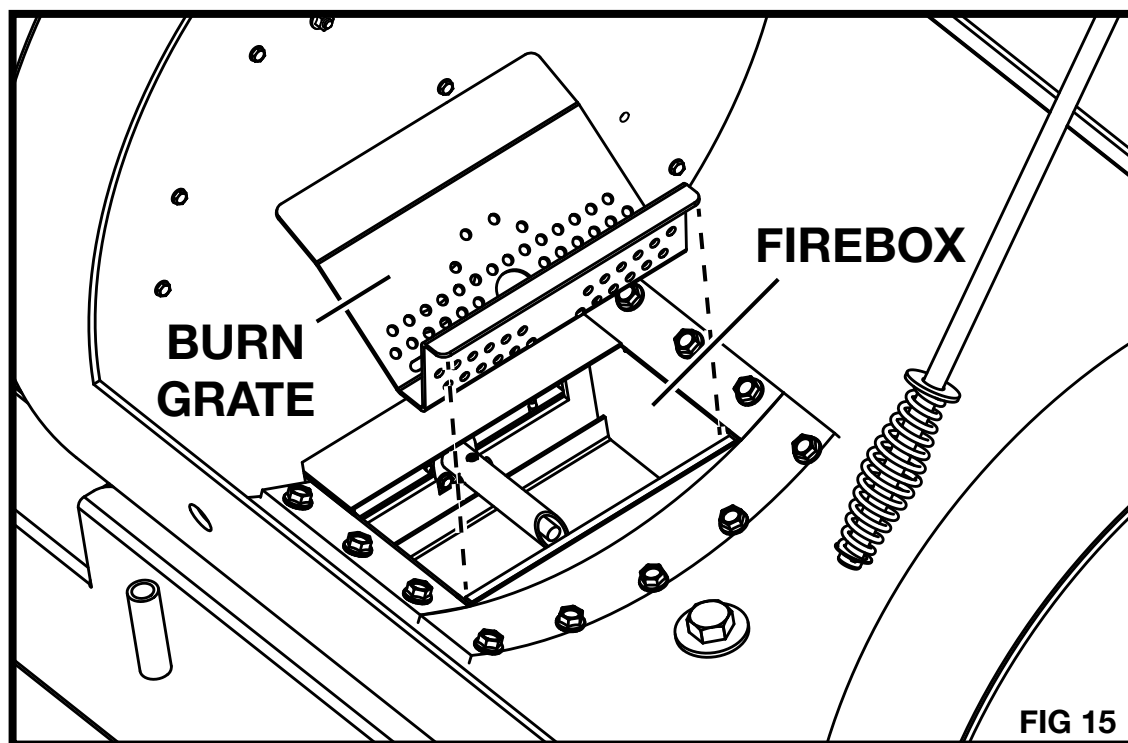

FIG 14

YS 1500

7. Check to see that the burn grate is properly seated in the firebox.



8. Place 1/8 cup (about a palm full) of pellets on the burn grate.

NOTE: This step is only necessary when the unit is first put into service or if it runs out of pellets.

9. Reinstall the heat management plate and cooking grates (See **FIG 14**).

10. Turn the power switch “on.” This starts the combustion air fan and illuminates the power light. Press the “start” pad on the control panel to activate the auger feed system. (The default temperature set point is 350°F). If a higher or lower temperature setting is desired, use the increase/decrease buttons to set the temperature. This can be adjusted at any time after the start cycle is activated. (For cool/cold season or high temperature cooking see the Selectable Heat Up Modes [Page 11]).

Once the start cycle is activated three lines will appear on the display panel from lower left to upper right indicating “heat up” mode. Once the grate temperature reaches 110°F, the actual grate temperature is displayed, alternating with the mode lines.

If the grate temperature range is exceeded during the “heat up” mode, dashing lines will appear from upper left to lower right indicating “cool down” mode. Once the target temperature range is attained the lines will flash horizontal indicating “maintenance mode”. The controller will display grate temperatures when the set point is between 150 to 495°F When the set point is between 500 to 600°F, the display will show the set point and not the actual grate temperature.

YS 1500

11. Flames should be visible on the burn grate within three to four minutes. (The igniter is active for two minutes. When you hit “start” the auger turns continuously for 45 seconds to prime the burn grate, at 46 seconds the igniter is powered, within two minutes the heat from the igniter and the combustion air from the fans will have a small smoldering fire started.

NOTE: The only way to reactivate the igniter is to turn the cooker off and let it go through the cool down cycle or simply pull the plug for a hard reset at which point you can restart the cooker. Before restarting the Yoder remove the grates and heat management plate and inspect the burn grate for any pellet overflow. Remove all pellets from the burn grate area and from the pit floor if present.)

12. Once the temperature reaches the set point, open the cooking chamber and carefully oil the grates with vegetable oil. You’re ready to cook!

Shutting Down The Smoker

When finished cooking push the power switch to the “off” position. The controller will begin its automatic shutdown procedure.

- The auger feed system will stop feeding fuel.
- The combustion cooling fan will continue to run until the fire is burned clean.
- The fan will continue to run until the grill temperature reaches 125°F or 18 minutes, whichever occurs first.
- When the procedure is complete the fan and power LED will turn off.
- Disconnect the Yoder from its power source. When the grill is completely cool, cover the grill to protect your investment and keep the pellets dry.

YS 1500

Manual Start Up

Here are the steps to manually light the grill in the event that the igniter fails. (Steps 2 & 3 only apply if the igniter has developed a dead short and is tripping the GFI or blowing the fuse.)

- 1) Remove the cooking grates, second shelf, heat management plate plates and the burn grate.

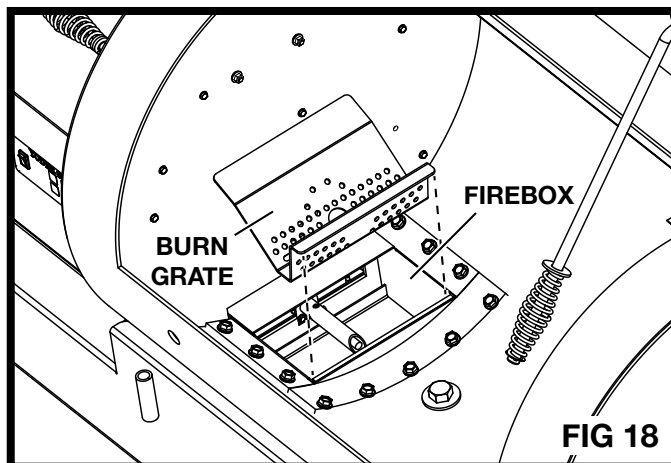
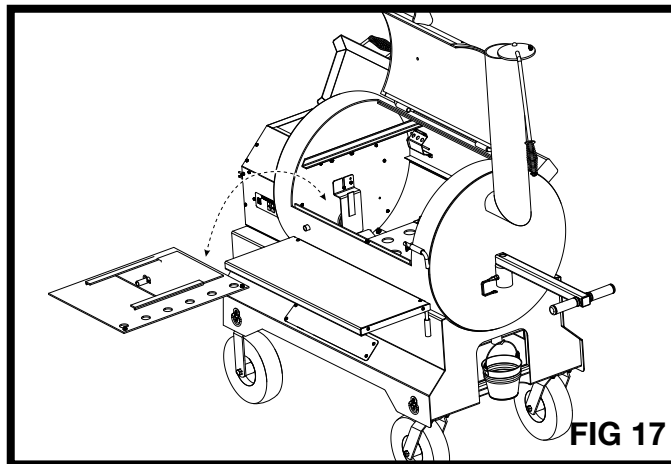
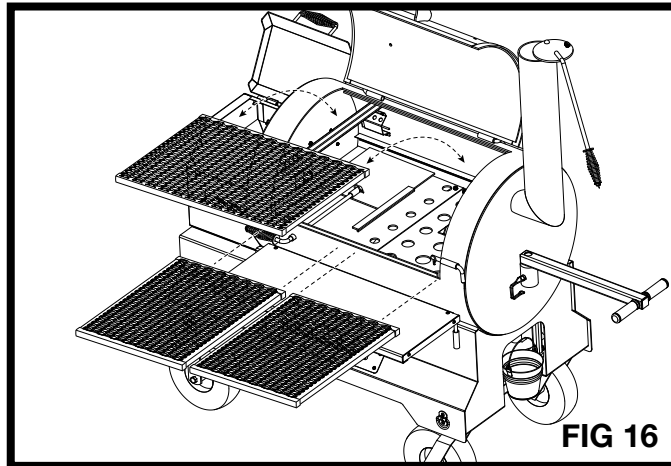

YS 1500

2) Reach into the hopper cavity on the left side of the igniter tube and pull the igniter wires into the firebox.

3) Unplug the igniter's weather tight connection and then push the wires back into the hopper cavity.

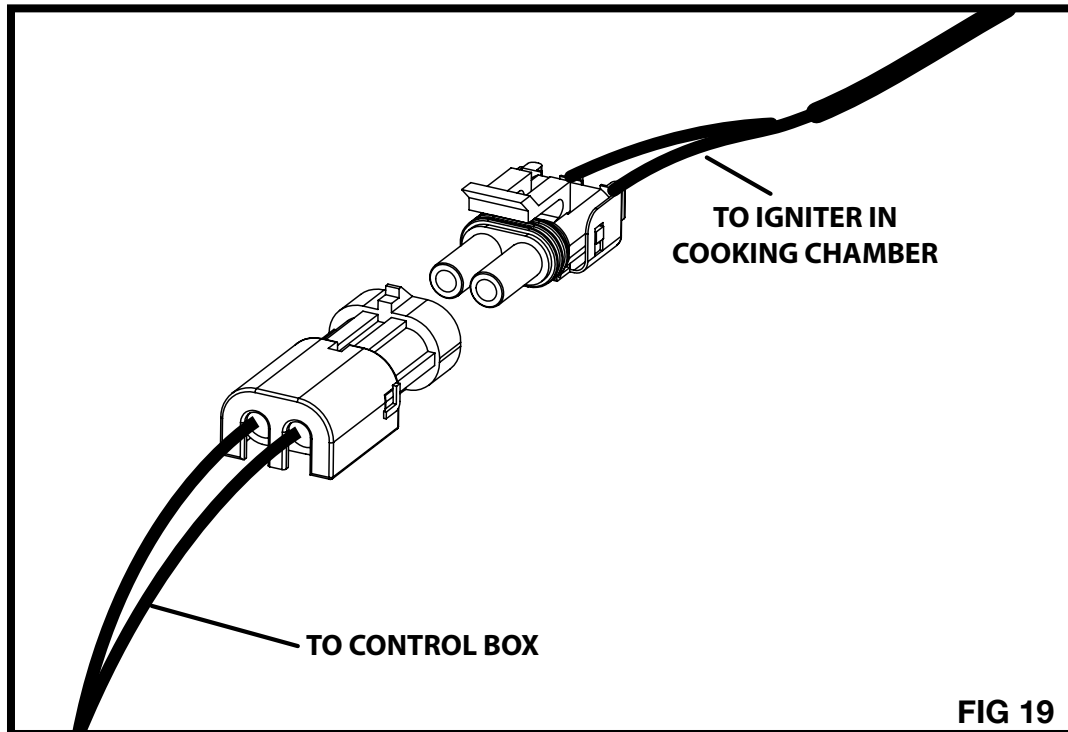

4) Reinstall the burn grate and place a small handful of pellets onto the grate.

5) Light the pellets with a torch, starter gel or starter stick.

6) Once lit, turn the power switch to the "on" position and press start on the control panel:

- The feed system begins the prime cycle and then defaults to the set temperature feed rate.
- Set the desired cooking temperature (default set point is 350°F).
- Your smoker will begin to produce a smoke during "startup" within approximately three to five minutes. To check if the pellets ignited, open the smoker and a flame should be visible in the burn pot area. You will be able to view this without having to touch any hot surfaces.

YS 1500

Getting the Most From Your Yoder: Direct & Indirect Grilling, Smoking & Baking

Heat Up Times and Grate Temperatures

The question is regularly asked: “How long does it take from the time I press “start” until I am ready to cook?”

When the cooker is setup traditionally (diffuser plate installed) the heat up time is 20 to 30 minutes. When the cooker is setup for direct and indirect grilling (diffuser plate out) the heat up time is about 15 minutes.

It is also important to note that when the cooker is setup “direct” the temperature at the center of the grate is hotter than the reported temperature. How much hotter depends on the set point, at 350°F. on the display, the grate center is approximately 425°F at 475°F on the display, grate center is approximately 625°F. The difference is caused by the reduction of airflow to the thermocouple when the direct grates are installed. This is true with the diffuser in or out.

Finally, precise temperature management is not important when you are doing short cooks where you are opening and closing the pit frequently. Find a set temperature that works well for the type of food you are grilling... for instance burgers and brats do well at a 350°F set point.

The versatility of your Yoder is realized by choosing one of its three unique setups: with the diffuser in place: smoking at 150 to 275°F; indirect grilling, 275 to 350°F and baking at 350 to 400°F Finally, for direct grilling where searing temperatures are desired simply remove the heat management plate and install the Grill Grate Direct Grill option.

The traditional setup for the Yoder has the heat management plate between the firebox and the cooking grates. With this setup, the cooking style is best described as a wood-fired oven. This setup is ideal for all of your smoked and baked foods.

Setup #1: Smoking and Baking. Heat management plate in and standard cooking grates installed. Leave the heat management plate closed. See **FIG 20**.

YS 1500

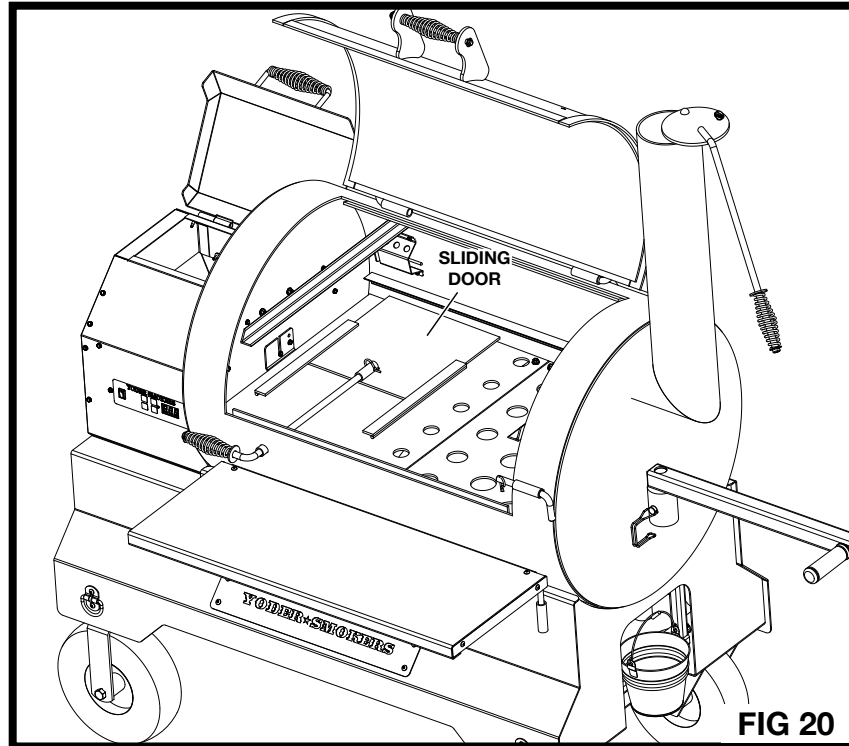

Setup #2: Moderate temperature grilling such as wings and boneless chicken breasts (grate temperatures up to 350°F): Heat with the diffuser plate in place and a set of Grill Grates installed on the left side of the cooker. The “Direct Grilling Kit” consists of three custom-made aluminum panels and replaces one standard cooking grate (see FIG 21). Option: Two sets of grill grates for extended direct grilling surface.

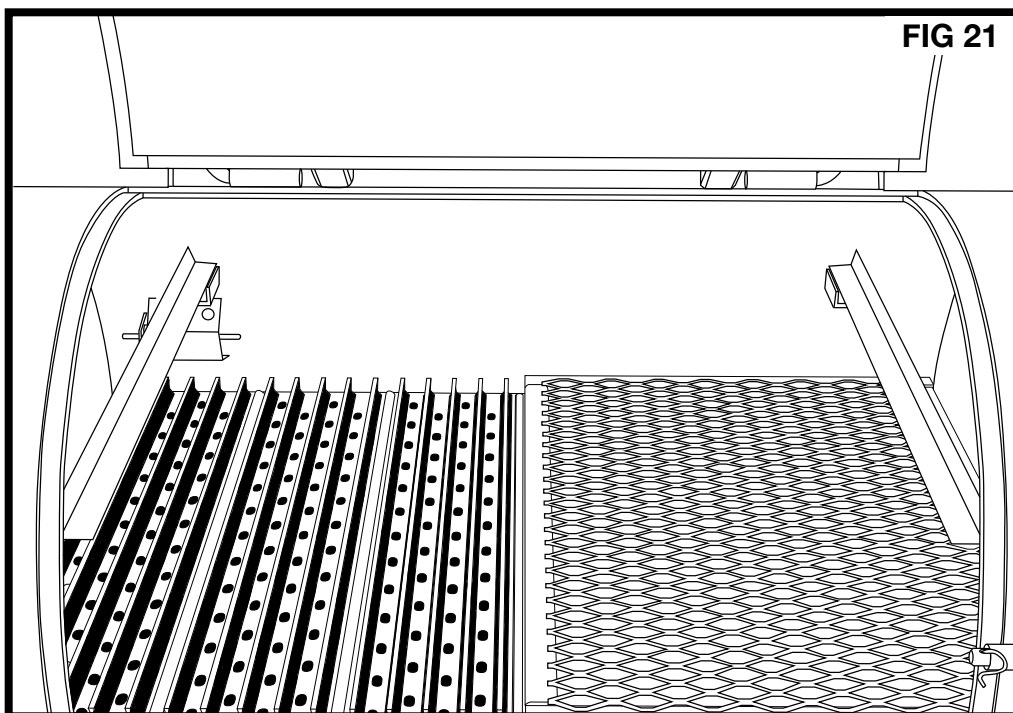

YS 1500

Setup #3: Direct grilling with searing capability: Open the sliding door on the heat management plate and install the Grill Grates on the left side of the cooker. When setup direct, (heat management plate out, one set of Grill Grates and one standard cooking grate installed) the Yoder creates a true direct/indirect cooking environment.

With a second set of Grill Grates installed on the right side of the Yoder, temperatures are fairly even across the entire cooking surface.

Heat Management Plate

The sliding door can open to allow for a higher cooking temperature. See **FIG 22**. If the sliding door is closed, it creates an even cooking temperature.

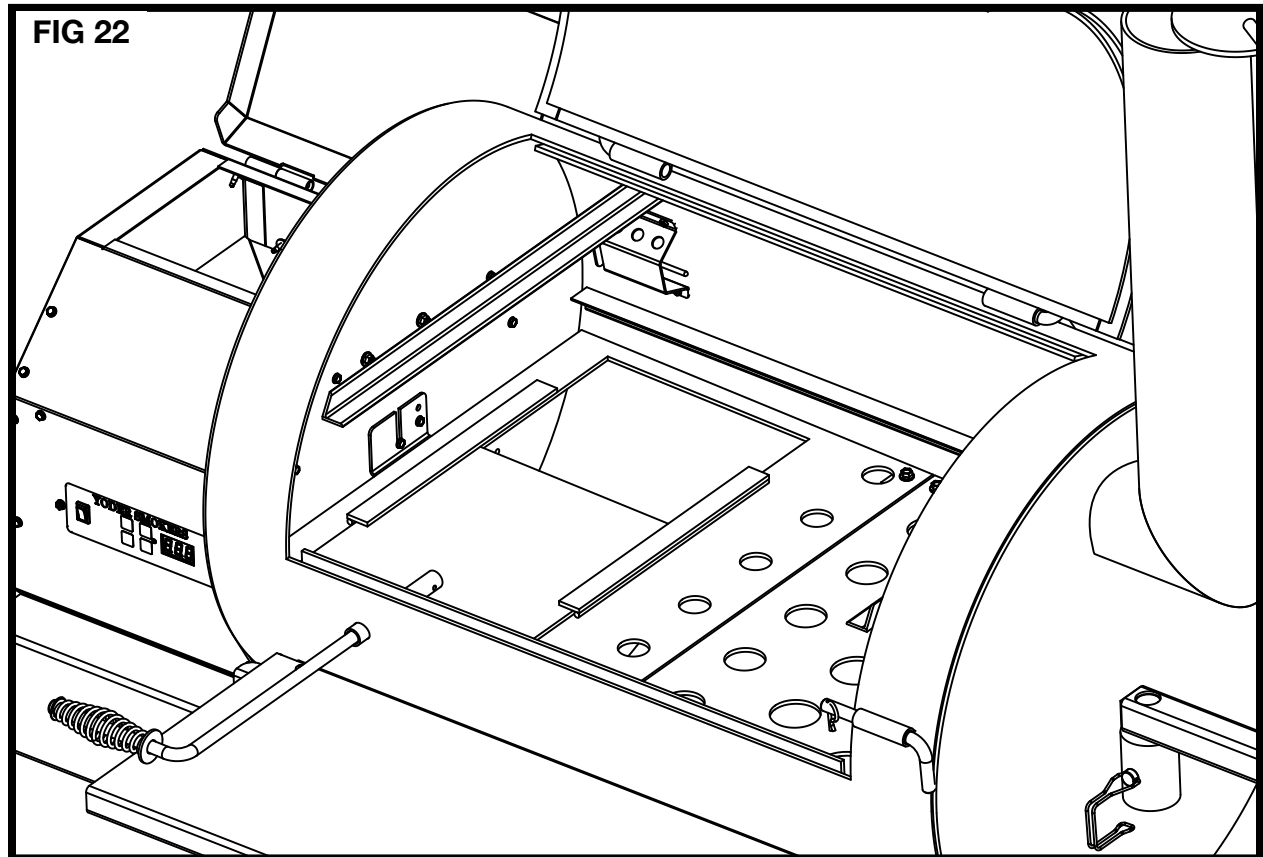

YS 1500

Grill Maintenance

Preparing the Grill for the Season

Begin with a thorough inspection of the entire grill correcting any issues you find. Follow the steps found in the Pre-Grill checklist (Page 15).

Painted Surfaces

Yoder smokers are painted with high heat silicone paint. When cleaning the smoker, surfaces should be washed down with warm soapy water using a neutral detergent and rinsed with clean water. For more information about high heat paint that can be used for touch-up, contact service@yodersmokers.com.

Cooking Grates

When new, wash thoroughly with warm soapy water, place back in the smoker and lightly coat with vegetable oil. Condition the grates during the burn off process.

When you begin the next cooking session, bring the grill up to the desired cooking temperature and use a long handled grill brush to clean the grates and then evenly coat the grates with vegetable oil.

Heat Management Plate

Any excess grease can be cleaned up using a plastic scraper and paper towels. You can also use a citrus based cleaning solution to help de-grease the heat management plate.

Cooking Chamber

It is recommended that each time you run through the steps in the Pre-Grill checklist (Page 15) that you inspect and thoroughly clean the interior of the cooking chamber. Any excess grease can be cleaned up using a plastic scraper and paper towels. Pay particular attention to the grease buildup along the bottom of the cooking chamber. At the beginning of the season and then as often as needed you should de-grease the interior with citrus based cleaning solution.

- Ensure that the grill is **completely cold** before using a shop vacuum or before scooping out and disposing of the ashes. Dispose of the ashes in a metal container.
- Use a citrus based cleaning solution to clean the entire inside of the body. This will control grease build-up and the possibilities of flare-ups.

YS 1500

Firebox and Burn Grate Assembly Maintenance

It is recommended that the firebox assembly is regularly inspected to be certain that it remains free of ash and debris which will insure proper performance.

The firebox is a fully welded structure that carries the burn grate and channels the combustion air. The firebox is bolted to the cooking chamber floor and the seams on the hopper wall and the floor of the cooking chamber are sealed with a high temperature silicone. Perform regular inspection of the silicone seal particularly on the top side of the firebox along the hopper wall. If this seal is broken, remove the old silicone, clean the surface, reapply new high temperature silicone and let it cure. We recommend using **Permatex 81878** high temperature silicone.

The seating of the burn grate into the firebox is critical for proper grill performance. Begin by resting the right hand side of the burn grate to the fire pot and then pressing down on the left hand side of the burn grate until fully seated. Once the burn grate is seated there is little to no movement in this assembly. Also, check to be certain that the igniter assembly is centered in the respective hole in the burn grate.

Stainless Steel Burn Grate

It is important to regularly check the combustion air holes located on the floor and sides of the burn grate for any blockage or build-ups. Using a wire brush or flat-head screwdriver, scrape off any build-up or debris.

Burn Grate Inspection

NOTE: Only do this when the smoker is completely cool.

To insure that the pit is burning efficiently, a visual inspection of the burn grate is required periodically. The burn grate should sit flat against the back wall. Due to the intense heat that is created the burn grate can change shapes. There should be no more than a 3/16" gap from the back wall to the burn grate. If a gap does exist then it must be corrected to insure proper pellet burning. To get to the burn grate see Page 15.

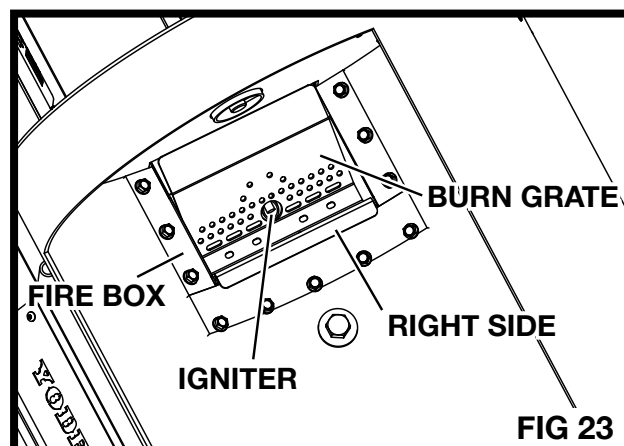

YS 1500

If the gap is greater than 3/16" the below steps should be followed.

1. Start by removing the burn grate from the firebox and placing it on its top.
2. Next, step on the burn grate and apply enough pressure to bend it back to its original shape. **DO NOT** apply too much pressure or you will overcorrect the burn grate and it will not fit back into the firebox.

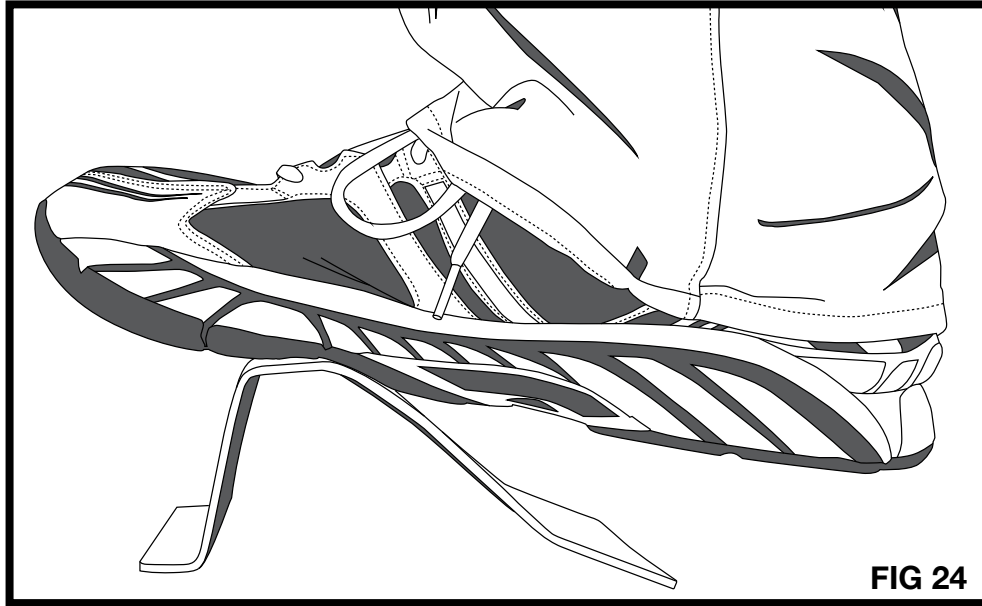

3. Place the burn grate back into the firebox and check the gap between the back wall and the burn grate to insure a proper fit. If a gap still exists then repeat steps 1 and 2.

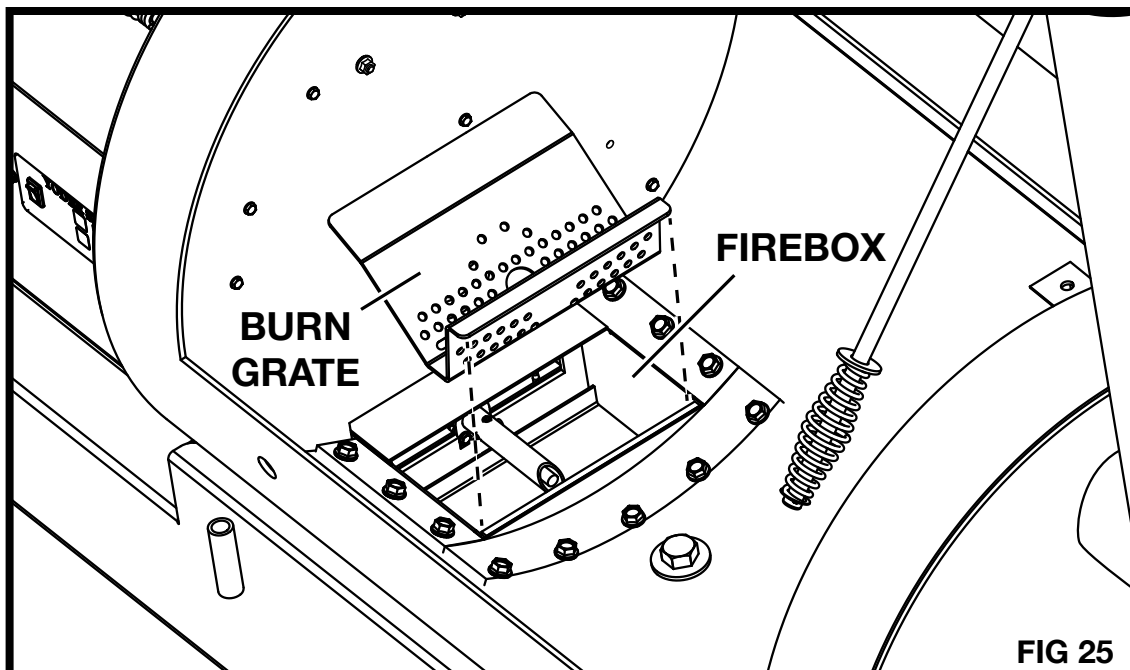

YS 1500

Igniter

When inspecting the firebox assembly, confirm that the igniter assembly, tube and igniter rod are free of ash or other debris. Periodically check the four set screws that secure the igniter rod into the tube. (See **FIG 26**). Verify that the igniter rod is centered in the tube and that the tip of the igniter rod is extended approximately 1/8" out from the igniter tube.

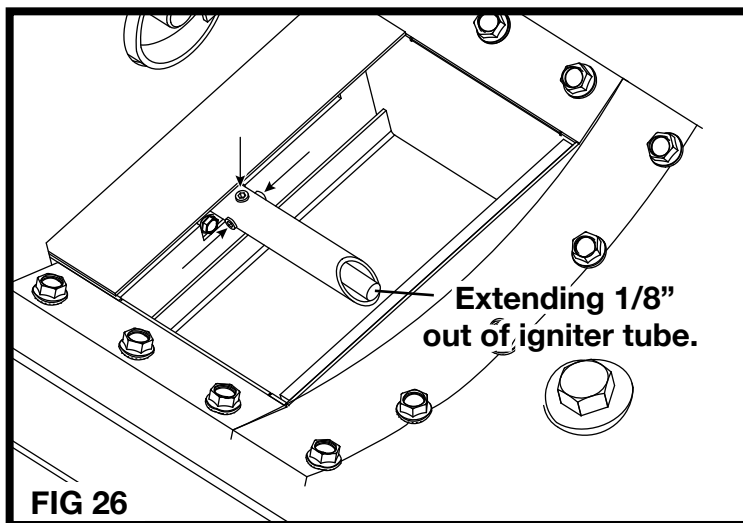

Fan Cooled Hopper Assembly

Always disconnect the power to the grill before performing any service

1. Remove any debris from the combustion air fan intake. Use compressed air to remove dust and debris from both fans.
2. Inspect and clean the pellet hopper area. The interior hopper surface can be wiped down using warm water and detergent. To protect the surface, and promote smooth pellet feeding, coat the surface with car wax.
3. Inspect the metal auger area and remove any debris or sawdust that may have built up.
4. Using a 5/16" socket you can remove the 11 screws securing the end panel to the hopper assembly (See **FIG 27**). This will allow you to perform the following:
 - Check and clean any debris within the hopper housing.
 - Check and clean any debris in the fan blades or housing.
 - Check and clean any debris from the auger motor.
 - Visually inspect the wiring harnesses and terminal connections.
5. Upon inspection (and any required maintenance) replace all screws. Hand start each screw to ensure proper threading.

YS 1500

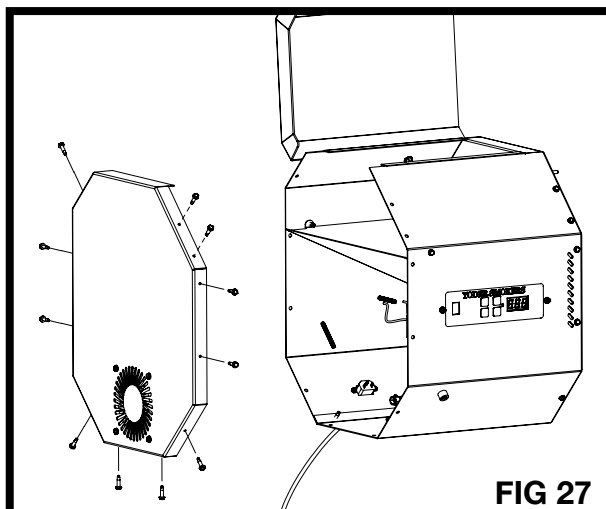

Grease Management Area and Bucket

Always be sure the grease catch area is clean and free of debris and empty the grease bucket regularly.

Additional Maintenance:

In addition to regular cleaning, perform the following procedures every 30 days:

1. Use a stiff brush to remove any build-up on the inside walls of your grill. Inspect and clean the inside of the lid, the heat management plate and the inside walls of the cooking chamber.
2. When your grill is cool to the touch use a shop vacuum to thoroughly clean the cooking chamber, firebox and hopper assembly.
3. Use a citrus based cleaning solution to thoroughly clean the inside of the grill.
4. Finally, visually inspect the painted surfaces and touch up any scratches with high heat flat black paint.

Fuse Replacement

If there is no display on the control panel with the switch in the “on” position, check the power source to verify the GFI hasn’t tripped. If the power source is working, check the Yoder fuse. The fuse container is located on the left front side of the pellet hopper below the control panel (See **FIG 28**).

Verify that the control panel is in the “off” position and disconnect the Yoder from its power source. Insert a small flat blade screwdriver into the slot on the top of the fuse container and twist it counterclockwise to open. If the fuse is blown, replace it with the supplied replacement fuse. (The fuse is a 5-milliamp slow blow fuse.) Reconnect the power and turn the Yoder on. If the fuse blows again, contact us for technical support.

YS 1500

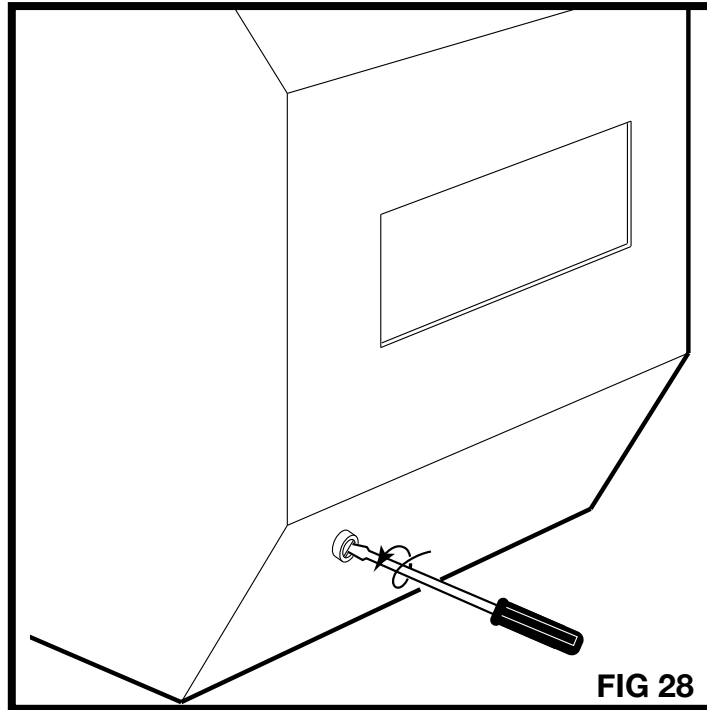

Storing Your Grill

Cover your Yoder Smoker to protect it from the weather and to keep the pellets dry. If storing your cooker inside, be sure the smoker is cool to the touch before moving it inside. Inspect the hopper and cooking chamber for any remaining embers before storing the unit.

1500 COOKING COMPONENTS

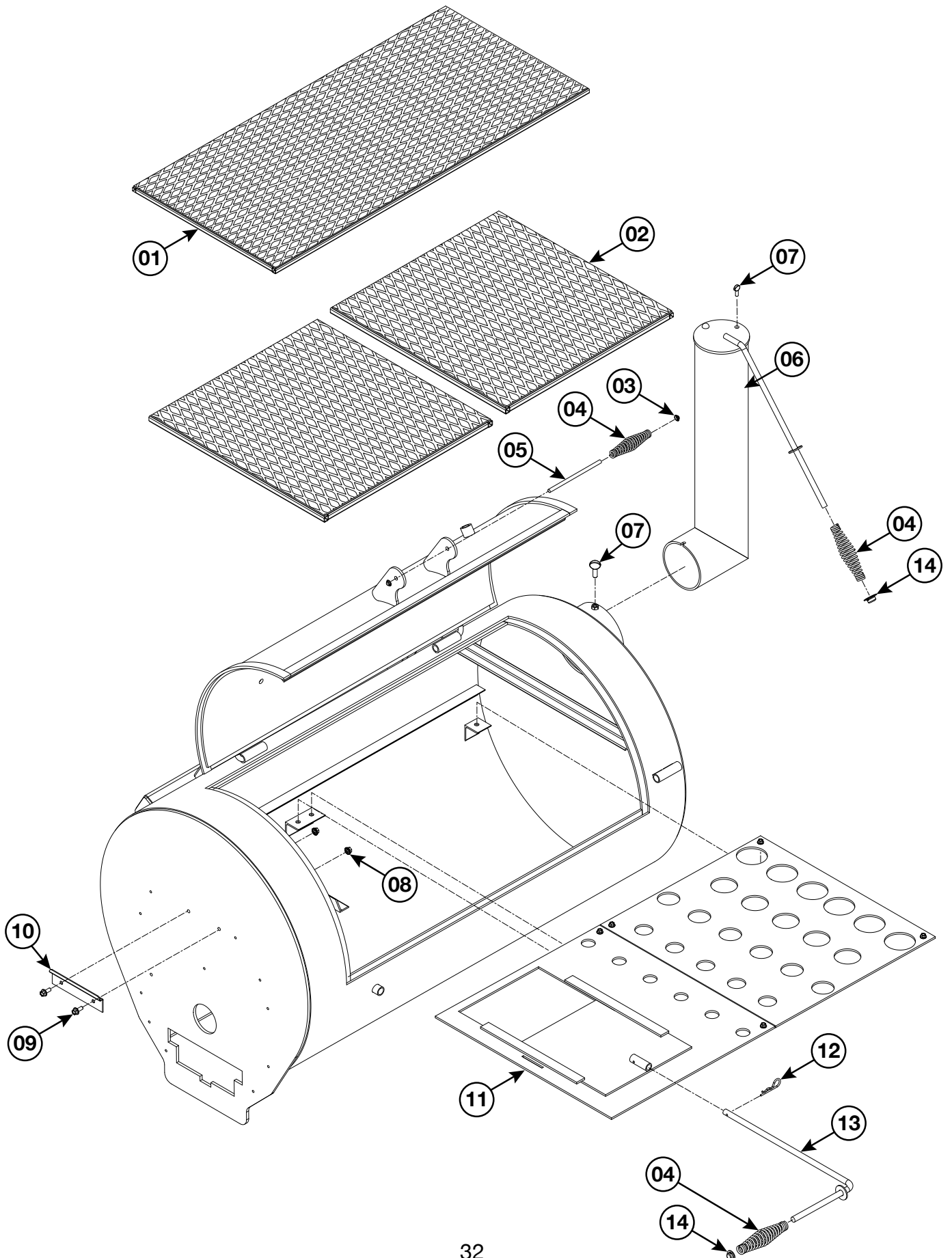

1500 COOKING COMPONENTS

ITEM #	PART #	DESCRIPTION	QTY.
1	W90820	YS 1500 2ND SHELF	1
2	W90827	YS 1500 COOKING GRATE	2
3	22924	3/8 PUSH CAP	1
4	22866	SPRING HANDLE	3
5	41435	HANDLE ROD	1
6	W90591	CHIMNEY YS1500	1
7	90377	THUMBSCREW	2
8	1420WHN	1/4-20 WHIZ NUT	2
9	1420X 58WHB	1/4-20 WHIZ BOLT	2
10	90117	HOPPER MOUNT BRACKET	1
11	W90834	HEAT MANAGEMENT PLATE	1
12	701-212-02	COTTER PIN	1
13	W90866	HEAT MANAGEMENT HANDLE	1
14	23108	1/2" PUSH CAP	2

1500 IGNITER AND THERMOCOUPLER COMPONENTS

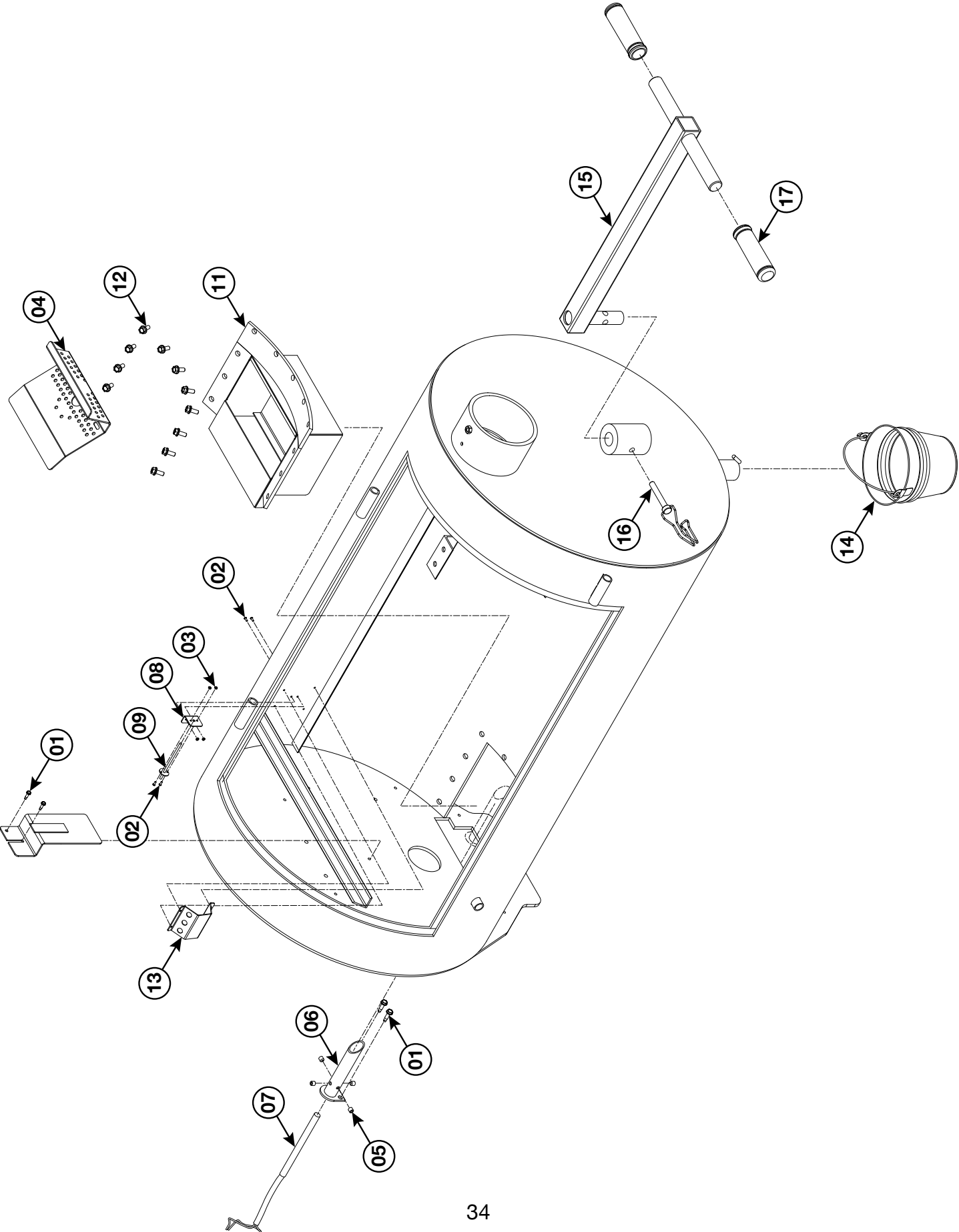

1500 IGNITER AND THERMOCOUPLER COMPONENTS

ITEM #	PART #	DESCRIPTION	QTY.
1	10X34HHSDS	SCREW, HEX HEAD, SELF DRILLING, 10 X 3/4	4
2	632X38MS	SCREW, MACHINE, ROUND HEAD, 6-32 X 3/8 LONG	8
3	632HN	NUT, HEX, 6-32	8
4	90005	BURN GRATE	1
5	1420X14SHSS	SCREW, SET, SOCKET HEAD, 1/4-20 X 1/4	4
6	W90026	IGNITER TUBE	1
7	A90494	IGNITER ASSEMBLY	1
8	90461LFP	THERMOCOUPLER MOUNT	1
9	90454	THERMOCOUPLER	1
10	W90809	AUGER COVER	1
11	W90811	FIREBOX	1
12	51618X34WHB	5/16-18 WHIZ BOLT	11
13	90727	THERMOCOUPLE HEAT SHIELD	1
14	90460	BUCKET	1
15	W44144	PULL HANDLE	1
16	120044	SNAPPER PIN	1
17	23868	RUBBER GRIPS	2

1500 HOPPER/COMP CART INSTALLATION

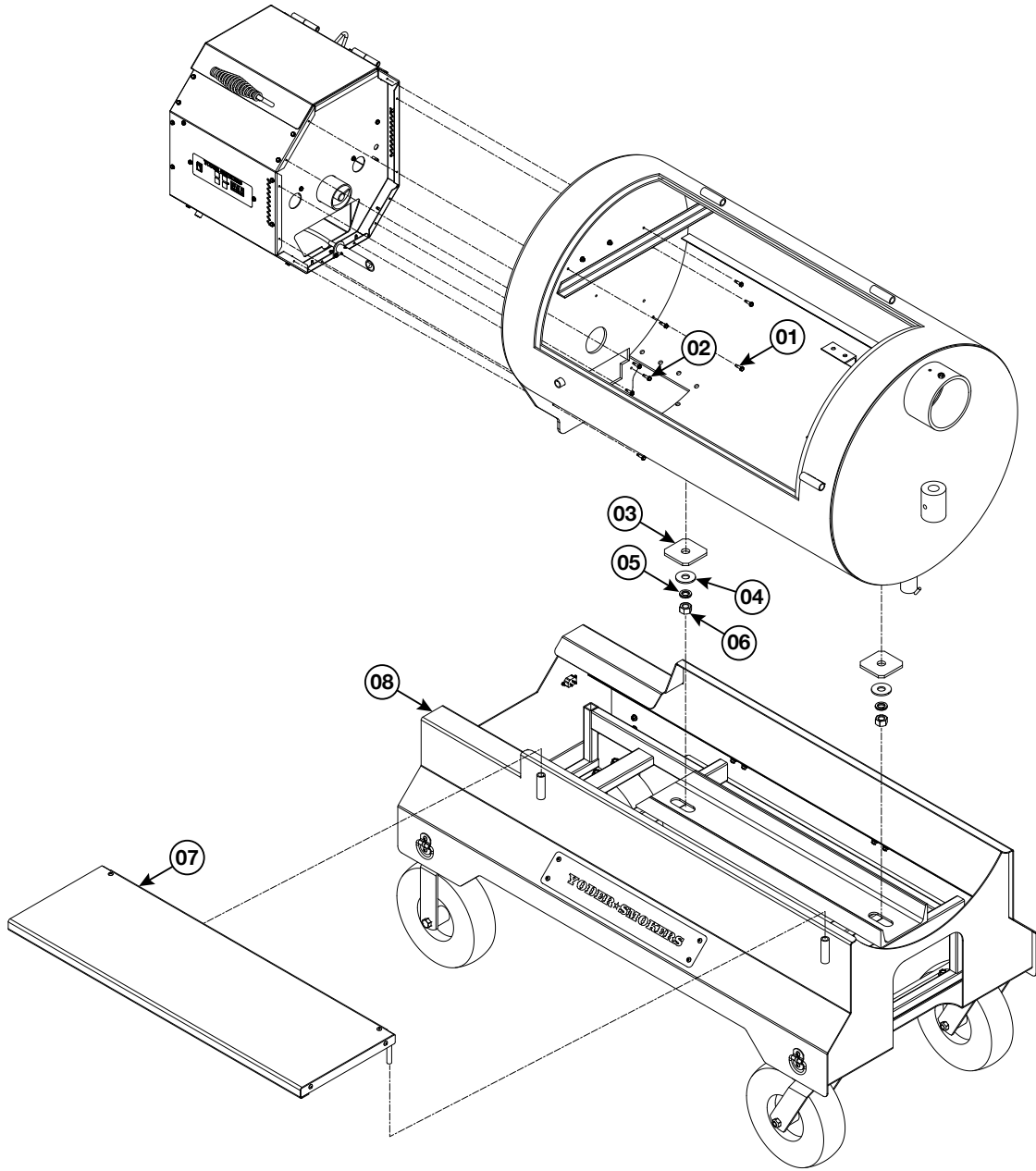

ITEM #	PART #	DESCRIPTION	QTY.
1	10X34HHSDS	SCREW, HEX HEAD, SELF DRILLING 10 X 3/4	10
2	1420X12HHSTS	SCREW, SLOTTED, HEX HEAD, SELF TAPPING, 1/4-20 X 1/2	2
3	41597	GRILL MOUNT TABS	2
4	58FW	5/8" FLAT WASHER	2
5	58LW	5/8" LOCK WASHER	2
6	5811HN	5/8-11 HEX NUT	2
7	A90830	STAINLESS FRONT SHELF	1
8	A90836	YS 1500 COMP CART ASSEMBLY	1

1500 TEMP GAUGES AND DOOR PIN

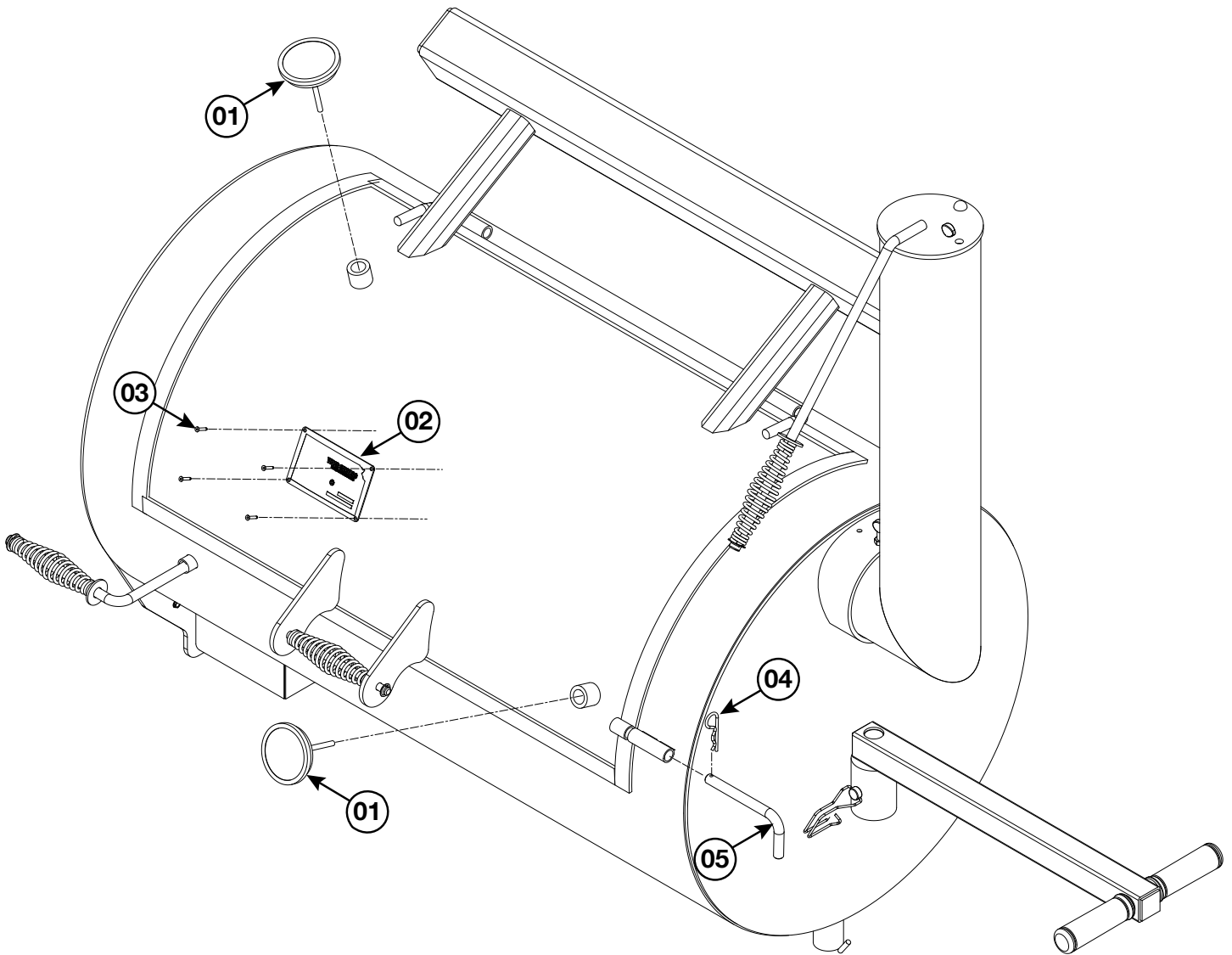

ITEM #	PART #	DESCRIPTION	QTY.
1	45200/24717	TEMP GAUGE 3"	2
2	22860	SERIAL PLATE	1
3	236-2489-02	POP RIVET	4
4	701-212-02	COTTER PIN	1
5	41301	DOOR LATCH PIN	1

1500 COMP CART

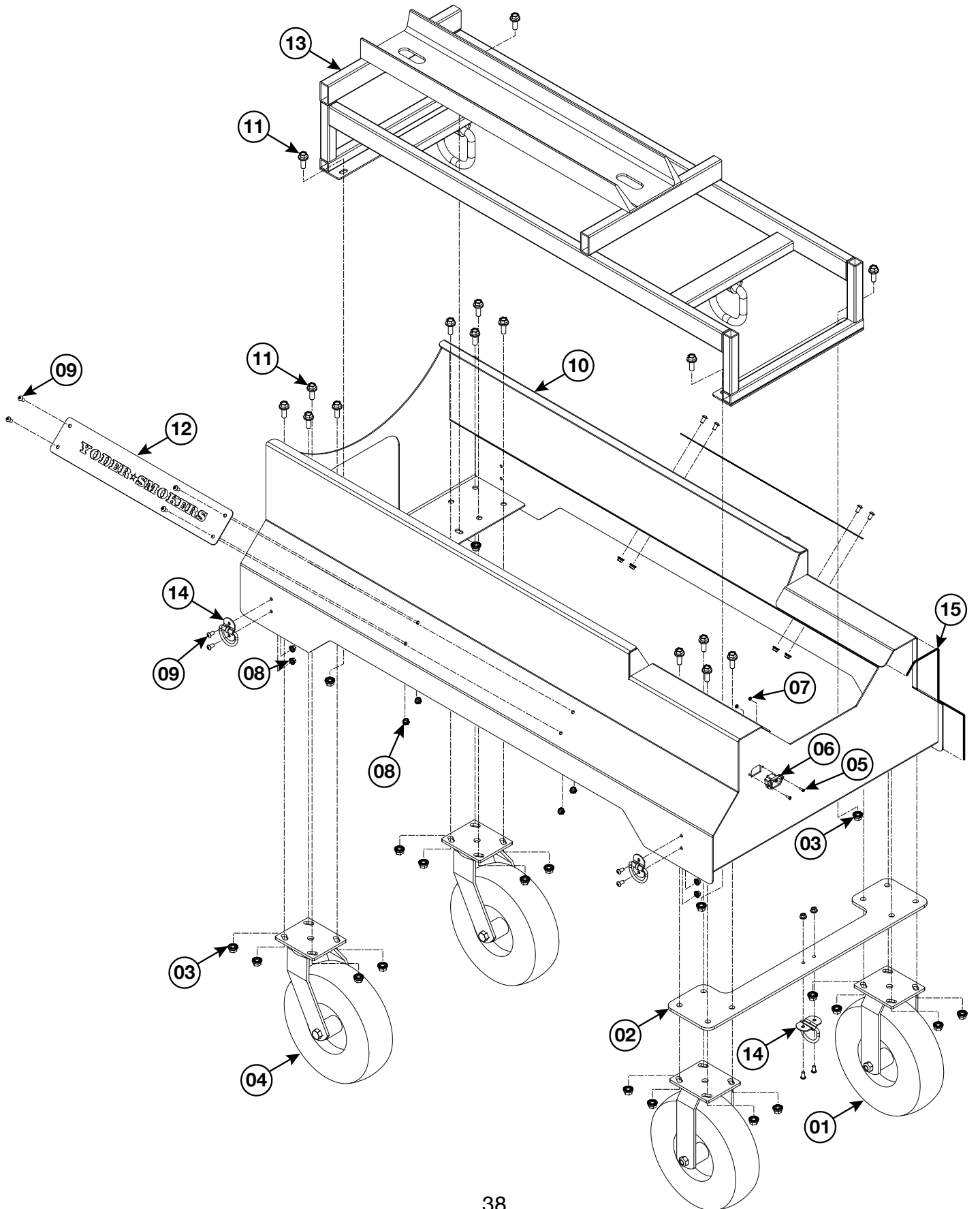

1500 COMP CART

ITEM #	PART #	DESCRIPTION	QTY.
1	90670	10" CASTER WHEEL	2
2	90716	CASTER RISER	1
3	3816whn	3/8-16 WHIZ NUT	20
4	90669	10" SWIVEL LOCK CASTER WHEEL	2
5	632X38MS	6-32 MACHINE SCREW	2
6	90312	POWER SOCKET	1
7	632HN	6-32 HEX NUT	2
8	1420WHN	1/4-20 WHIZ NUT	18
9	1420X12BHCSSS	1/4-20 BUTTON HEAD CAP SCREW, STAINLESS STEEL	18
10	W90837	YS1500 COMP CART	1
11	3816X1WHB	3/8-16 WHIZ BOLT	20
12	90527	YODER SMOKER PLACARD	2
13	W90840	YS1500 COMP CART FRAME	1
14	23848	D-RING	5
15	24117	BUMP GUARD	4

HOPPER ASSEMBLY

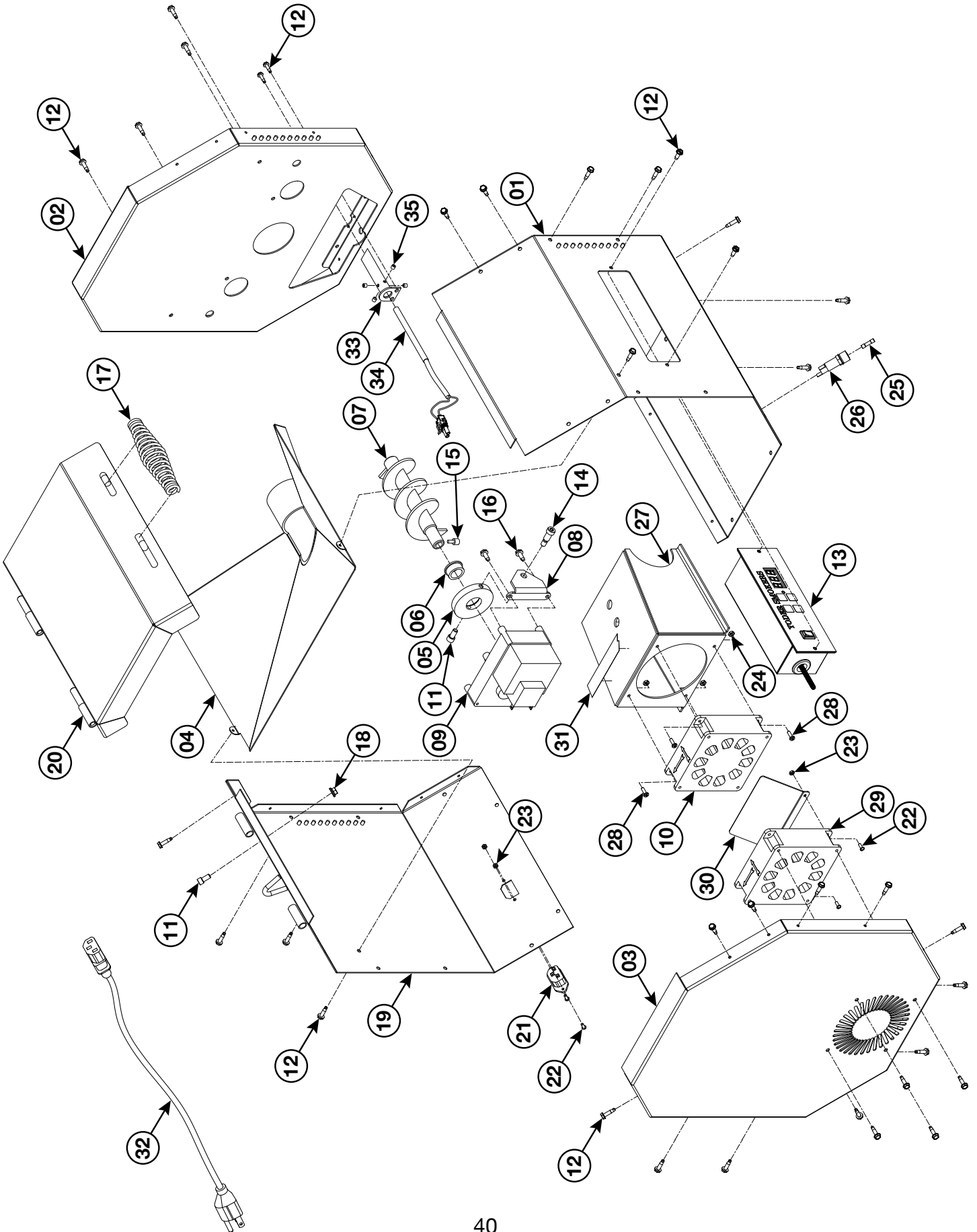

HOPPER ASSEMBLY

ITEM #	PART #	DESCRIPTION	QTY.
1	90101	BODY, FRONT, FEED COMPARTMENT	1
2	90102	BULKHEAD, MOUNT, HOPPER	1
3	90106	COVER, END, FEED COMPARTMENT	1
4	W90791	HOPPER, PELLET SMOKER	1
5	90022	BUSHING, AUGER	1
6	90023	BUSHING, AUGER	1
7	W90019	AUGER	1
8	90027	PLATE, ANTI-TORQUE	1
9	90899	MOTOR, PELLET AUGER	1
10	90060	OUTER FAN, 68CMF	1
11	1420X12SHCS	SOCKET HEAD CAP SCREW, 1/4-20 X 0.05 LONG	2
12	10X34HHSDS	SCREW, HEX HEAD, SELF DRILLING 10 X 3/4	37
13	A90152	CONTROLLER	1
14	516X12SHSB	SCREW, SHOULDER, .313 X .50, SOCKET HEAD 1/4-20	1
15	51618X12SHSS	SCREW, SET, SOCKET HEAD, 5/16-18 X 1/2	1
16	1024X12HHSTS	SCREW, SLOTTED, HEX HEAD, SELF TAPPING, 10-24 X 1/2	4
17	22866	HANDLE, SPRING	1
18	1420WHN	NUT, WHIZ, 1/4-20	1
19	W90790	HOPPER BACK	1
20	W90788	HOPPER DOOR	1
21	90312	SOCKET, 15 AMP	1
22	632X38MS	SCREW, MACHINE, ROUND HEAD, 6-32 X 3/8 LONG	4
23	632HN	NUT, HEX, 6-32	4
24	832HN	NUT, HEX, 8-32	4
25	90413	FUSE, 5A	1
26	90412	FUSE HOLDER	1
27	W90553	FAN HOUSING	1
28	832X12MS	SCREW, MACHINE, PHILLIPS HEAD, 8-32 X 1/2 LONG	4
29	90686	INNER FAN, 115 CMF	1
30	90893	PLATE, FAN AIR DIVERTER	1
31	23985	VELCRO	1
32	90313	POWER CORD	1
33	W90026	IGNITER TUBE	1
34	A90494	IGNITER ASSEMBLY	1
35	1420X14SHSS	SCREW, SET, SOCKET HEAD, 1/4-20 X 1/4	4

YS 1500

Warranty Information

Your Yoder YS1500 is fully backed by our exceptional customer support and warranties. The igniter is warrantied for one year; the 10-gauge cooking body for 10 years and the control system for three years.

Firmware updates are offered to users through our dealer network and by inquiry to our website. We will send a handheld programmer on loan and instructions for completing a firmware upgrade.

For product support contact: service@yodersmokers.com.