

★ **YODER SMOKERS** ★
COMPETITION GRADE BBQ PRODUCTS

Pellet Smoker
23931

PROCEDURE FOR INSTALLATION OF
PROBE PORT

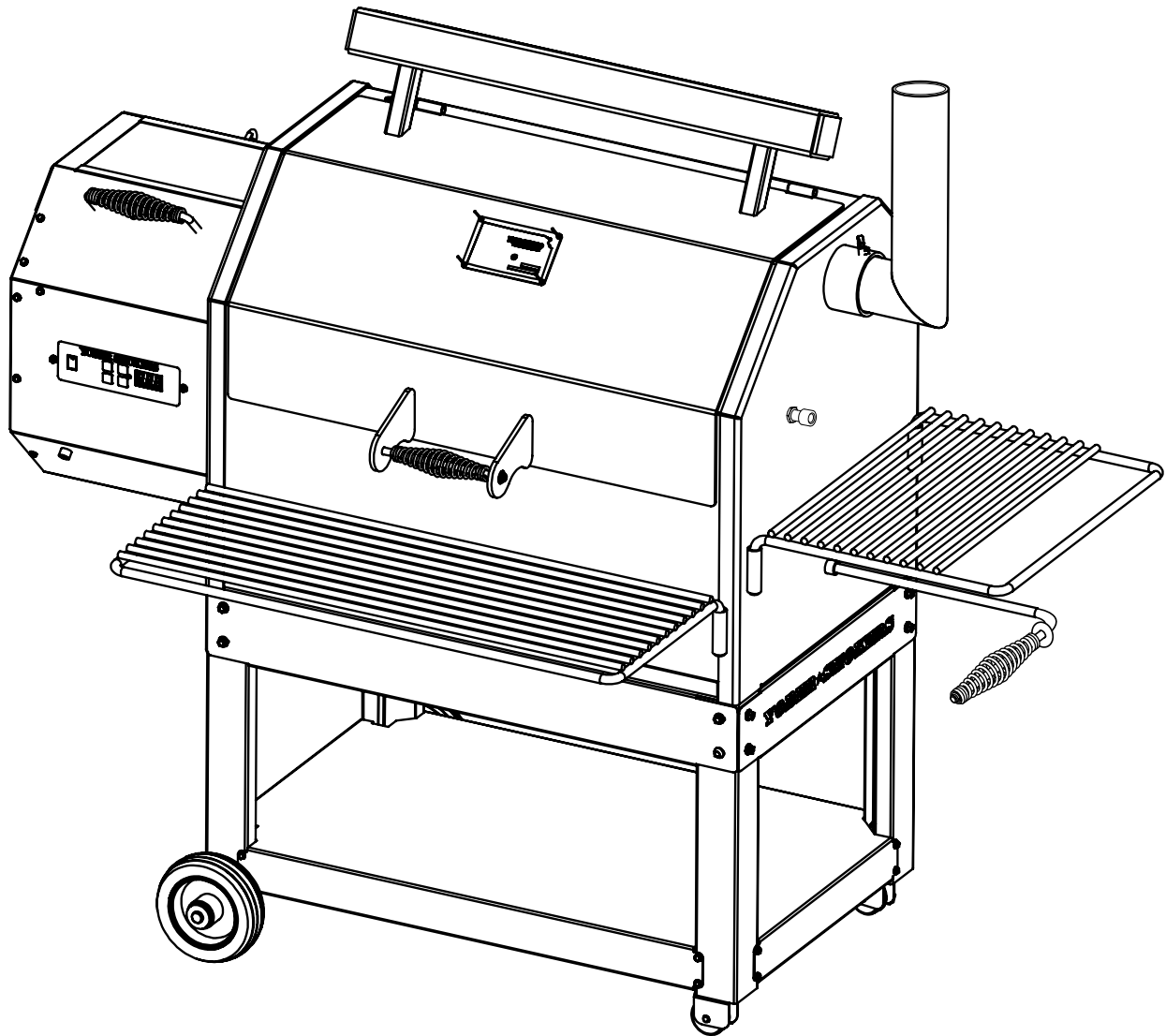

VERSION 2 - JAN, 2016

Install Probe Port in Pellet model YS480 or YS640 as follows:

TOOLS REQUIRED:

1. Tape Measure
2. Pencil
3. 1/4" Drill Bit
4. 5/8" Drill Bit
5. Drill
6. 18mm Wrench or Crescent Wrench

PARTS REQUIRED:

1. Part No. 23931 Probe Port

PREPARATION OF THE SMOKER UNIT:

1. Measure and mark location of hole on the side of the body with the smoke stack.

Place some easily removable tape, i.e. 2" painters tape, where the hole is to be drilled to protect the surface from scratches. Then re-measure the location for the hole and remove the tape when finished drilling. **FIG 1**

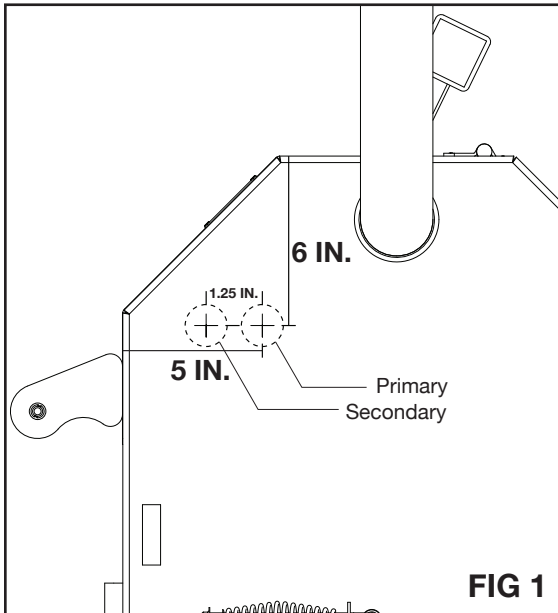

FIG 1

2. We recommend drilling a 1/4" pilot hole, then drill the hole with a 5/8" bit.
3. Insert probe port in hole. Secure the probe port with stainless steel hex nut using a 18mm wrench or crescent wrench. See **FIG 2**.

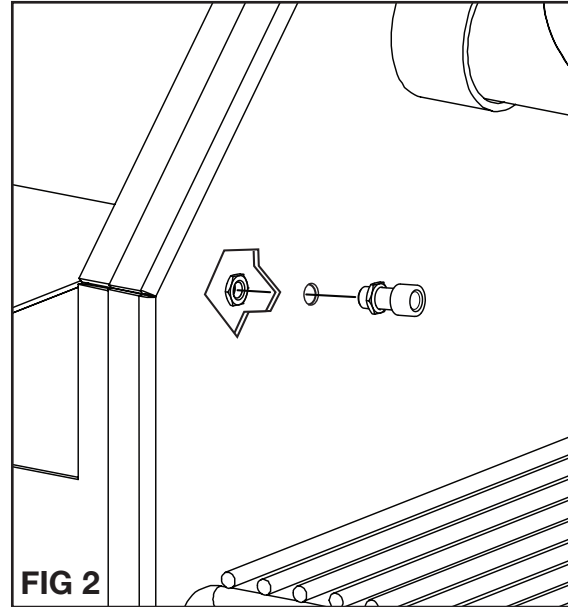

FIG 2

END OF PROCEDURE